

**ATTENZIONE - ATTENTION - ACHTUNG**

- Per lo smontaggio degli utensili utilizzare sempre la chiave di contrasto come indicato nel manuale d'uso.
- For disassembly of the tools use always the contrast key as mentioned in the user instructions.
- Fuer das Abmontieren der Werkzeuge immer den Gegenschuessel benutzen wie in der Bedienungsanleitung erwaeht.

- ATTENZIONE - ATTENTION - ACHTUNG**
- VERIFICARE LE MISURE DI INGOMBRO PER POSSIBILE INTERFERENZA SU ALCUNI MODELLI DI MACCHINE
  - Please check the overall sizes for possible interferences on some machine models
  - Bitte ueberpruefen sie das ausmass um moegliche interfeerenzen auf einigen maschinen modellen zu vermeiden

**ATTENZIONE - ATTENTION - ACHTUNG**

- PRIMA DI UTILIZZARE IL MOTORIZZATO CONSULTARE LE ISTRUZIONI ALLEGATE!
- BEFORE USING THE DRIVEN TOOL, PLEASE CHECK THE ENCLOSED INSTRUCTION SHEET!
- VOR DER BENUTZUNG DES ANGETRIEBENEN WERKZEUGES, DIE BEILIEGENDEN INSTRUKTIONEN DURCHLESEN!

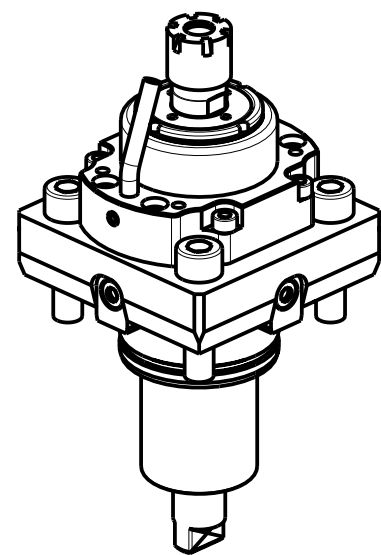

| Cod. MT    | Mandrino Spindle Spindel | I (n1:n2) | RPM max n2 | Coppia Max Max Torque Max Drehmoment M2 (Nm) | Lubrificazione int. Coolant through Innenkuehlung Pmax (bar) | Lubrificazione est. Ext. coolant Aussekkuehlung | Lav. secco Dry-run Trocken Bearb. | A      | CHIAVI INCLUSE Keys included Schluessel einbegriffen |
|------------|--------------------------|-----------|------------|--|--|---|-----------------------------------|--------|--|
| DW00600116 | ER16                     | 1:5.625   | 22500      | 6  | -  | X   | -                                 | 95.25  | CHMNER16 CHUB17                                      |
| DW00600111 | ER11                     | 1:5.625   | 22500      | 6  | 30   | X   | -                                 | 107.45 | CHMNER11 CHUB11                                      |

YCM  
 NT2000 16 STAZIONI - NTC1600/2000 M/LM/LS/Y/LY/LSY  
 MODULO MOTORIZZATO RADIALE Moltiplicato I=1:5.625  
 Radial geared-up I=1:5.625 driven tool  
 Radial angetriebenes Werkzeug uebersetzt I=1:5.625

**M.T. srl**  
 Via Casino Albini 480  
 Tel. 0541/956034-957884  
 Fax 0541/956341  
 47842 S. GIOVANNI IN M. (RN)  
 e-mail: mtma@mtmarchetti.com  
 http://www.mtmarchetti.com



YCM060-1-00

Subject to change without notice.