

### ATTENZIONE - ATTENTION - ACHTUNG

- VERIFICARE LE MISURE DI INGOMBRO PER POSSIBILE INTERFERENZA SU ALCUNI MODELLI DI MACCHINE
- Please check the overall sizes for possible interferences on some machine models
- Bitte überprüfen sie das ausmass um mögliche interferenzen auf einigen maschinen modellen zu vermeiden

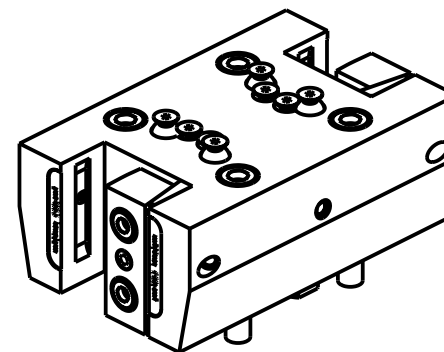
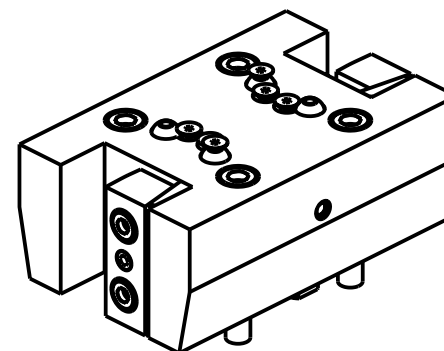

DW 04 352510

Cod. MT	N°Utensili N°Tools N°Werkzeuge	Reversibile 180° 180° Reversible 180° umsetzbar	Lubrificazione int. Coolant through Innenkuehlung Pmax (bar)	Lubr.esterna Ext. coolant Aussenkuehlung	Misure Dimensions Masse	B	H
DW 04 352500	2	X	-	X	mm	25	25
DW 04 352510	2	X	70	X	mm	25	25
DW 04 352540	2	X	-	X	Inch	1"	1"

NEW  
NEW

VICTOR

MOD: VTURN-A16/A20/A200 CM/SCM/YCM/YSCM - VTURN-A260 YCM/YSCM 16 ST.

PORTAUTENSILE RADIALE DOPPIO QD=25mm H=60mm

Radial double static tool QD=25mm H=60mm

Radial Doppel-Werkzeughalter QD=25mm H=60mm

Subject to change without notice.

**M.T. srl**

Via Casino Albini 480  
Tel. 0541/956034-957884  
Fax 0541/956341  
47842 S. GIOVANNI IN M. (RN)  
e-mail: mtma@mtmarchetti.com  
<http://www.mtmarchetti.com>



VCT453-1-00

09/2025