

### ATTENZIONE - ATTENTION - ACHTUNG

- VERIFICARE LE MISURE DI INGOMBRO PER POSSIBILE INTERFERENZA SU ALCUNI MODELLI DI MACCHINE
- Please check the overall sizes for possible interferences on some machine models
- Bitte überprüfen sie das ausmass um mögliche interferenzen auf einigen maschinen modellen zu vermeiden

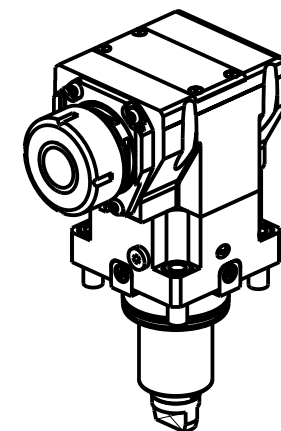
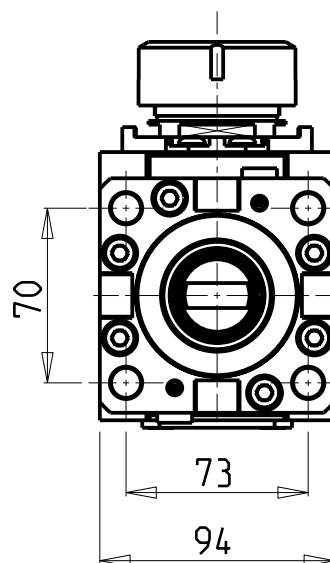

# ATTENZIONE: Non si monta su macchina VTURN-S26 CM

# WARNING: This tool can not be mounted on VTURN-S26 CM

# ACHTUNG: Werkzeug darf nicht auf VTURN-S26 CM montiert werden

• Chiave inclusa

• Key included

• Schlüssel inbegriffen

Cod. MT	Mandrino Spindle Spindel	I (n1:n2)	RPM max n2	Coppia Max Max Torque Max Drehmoment M2 (Nm)	Reversibile 180° 180° Reversible 180° umsetzbar	Lubrificazione int. Coolant through Innenkuehlung Pmax (bar)	Lubr.esterna Ext. coolant Aussenkuehlung	Lav. secco Dry-run Trocken Bearb.	A	A1	B	CHIAVI NON INCLUDE Keys not included Schlüssel nicht einbegriffen	
DW02360132	ER32	2:1	3000	130	X	-	X	X	98.7	-	53	OKU0650004	CHSTER32
DW02360232	ER32	2:1	3000	130	X	70	X	-	98.7	-	66.5	OKU0650004	CHSTER32
DW02360140	ER40	2:1	3000	130	X	-	X	X	101.7	-	53	OKU0650004	CHSTER40
DW02360240	ER40	2:1	3000	130	X	70	X	-	101.7	-	66.5	OKU0650004	CHSTER40
DW02360725	WELDON 25	2:1	3000	130	X	-	X	X	-	106	53	-	-
DW02360825	WELDON 25	2:1	3000	130	X	70	X	-	-	106	66.5	-	-

VICTOR

MOD: VTURN-A26 CM/SCM/YCM/YSCM - VTURN-A260 CM/SCM/YCM/YSCM 12 ST. - VTURN-S26 CM

MODULO MOTORIZZATO ASSIALE RIDOTTO I=2:1 H=100mm

Axial geared-down I=2:1 driven tool H=100mm

Axial angetriebenes Werkzeug untersetzt I=2:1 H=100mm

Subject to change without notice.

M.T. srl

Via Casino Albini 480

Tel. 0541/956034-957884

Fax 0541/956341

47842 S. GIOVANNI IN M. (RN)

e-mail: mtma@mtmarchetti.com

http://www.mtmarchetti.com



VCT190-2-30