

ATTENZIONE - ATTENTION - ACHTUNG

- Per lo smontaggio degli utensili utilizzare sempre la chiave di contrasto come indicato nel manuale d'uso.
- For disassembly of the tools use always the contrast key as mentioned in the user instructions.
- Fuer das Abmontieren der Werkzeuge immer den Gegenschlüssel benutzen wie in der Bedienungsanleitung erwäohnt.

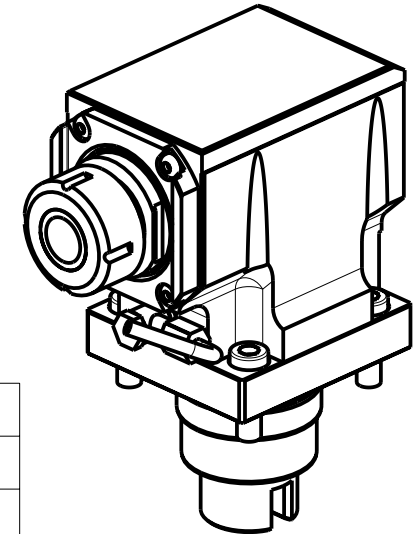

- Chiave inclusa
- Key included
- Schlüssel inbegriffen

| Cod. MT | Mandrino Spindle Spindel | I (n1:n2) | RPM max n2 | Coppia Max Max Torque Max Drehmoment M2 (Nm) | Lubrificazione int. Coolant through Innenkuehlung Pmax (bar) | Lubr.esterna Ext. coolant Aussenkuehlung | Lav. secco Dry-run Trocken Bearb. | A | A1 | D | L | B | CHIAVI NON INCLUDE Keys not included Schlüssel nicht einbegriffen | |
|-------------|--------------------------|-----------|------------|--|--|--|-----------------------------------|-------|----|----|----|------|---|------------|
| TKW 0110332 | ER32 | 1:1 | 6000 | 65 | - | X | X | 108.7 | - | - | - | 54.5 | CHSTER32 | OKU0650004 |
| TKW 0110432 | ER32 | 1:1 | 6000 | 65 | 100 (diag. 2) | X | X | 108.7 | - | - | - | 67 | CHSTER32 | OKU0650004 |
| TKW 0111527 | Ø27x21 | 1:1 | 6000 | 65 | - | X | X | - | 85 | 27 | 21 | 54.5 | CH_VTCROCE_M12 | OKU0650004 |

TAKISAWA
 MOD: EX308/310/508/510/708/710/910 - TT350 MC - NEX908/910 - LA250YS 15ST. - FX-800 - MX-800 - EX2000M/Y
 NX-2000 M/MS/Y/YS 12ST.
MODULO MOTORIZZATO ASSIALE PER CONTROMANDRINO
 Axial driven tool for subspindle
 Axial angetriebenes Werkzeug fuer Gegenspindel

M.T. srl
 Via Casino Albini 480
 Tel. 0541/956034-957884
 Fax 0541/956341
 47842 S. GIOVANNI IN M. (RN)
 e-mail: mtma@mtmarchetti.com
 http://www.mtmarchetti.com



TKW 155-2-10

Subject to change without notice.