

ATTENZIONE - ATTENTION - ACHTUNG

- VERIFICARE LE MISURE DI INGOMBRO PER POSSIBILE INTERFERENZA SU ALCUNI MODELLI DI MACCHINE
- Please check the overall sizes for possible interferences on some machine models
- Bitte überprüfen sie das ausmass um mögliche interferenzen auf einigen maschinen modellen zu vermeiden

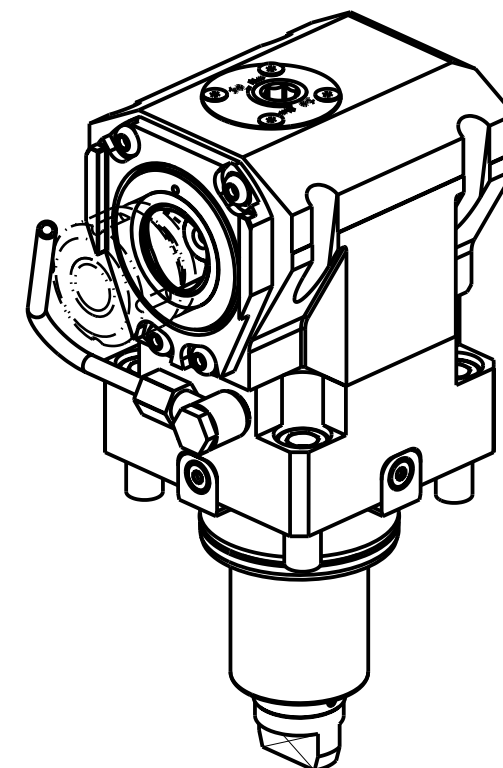
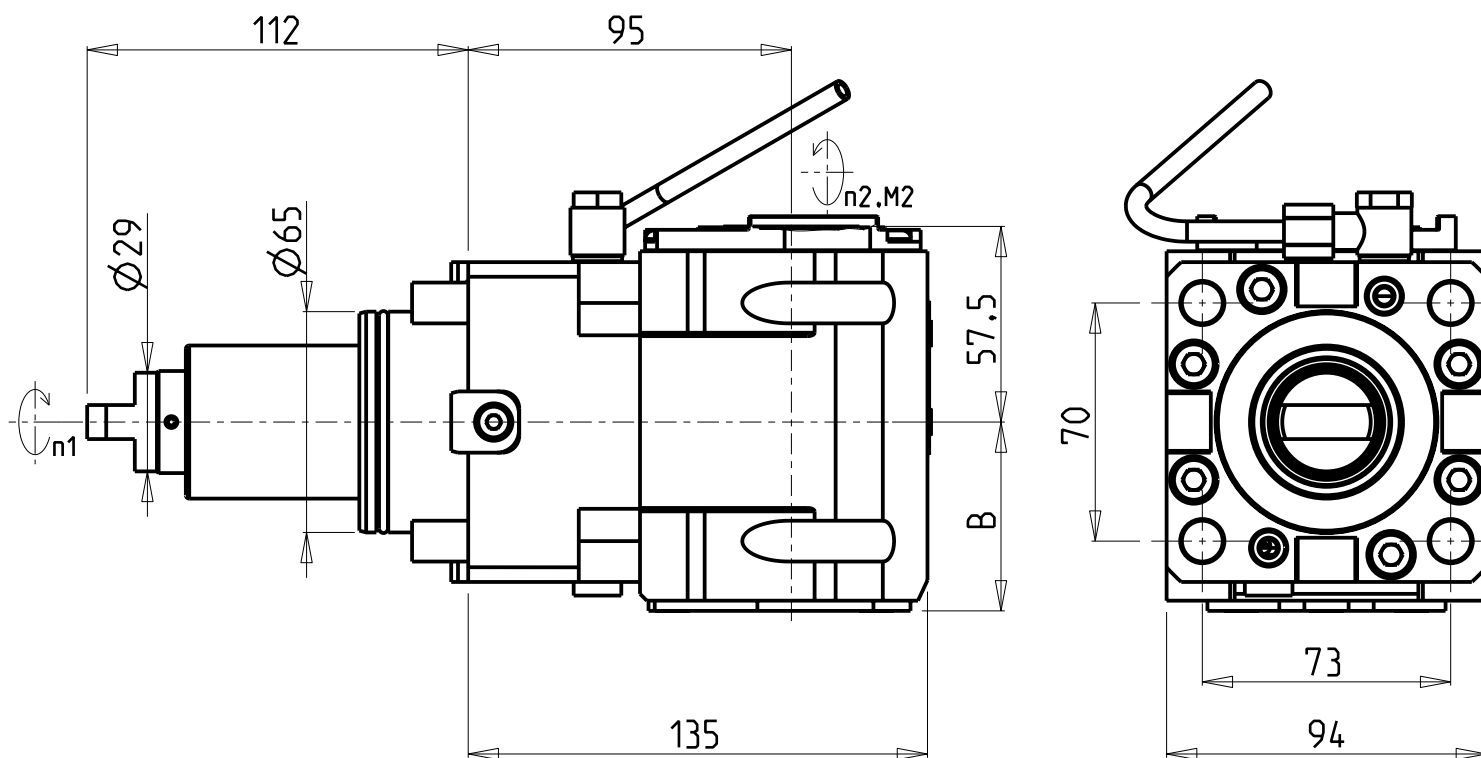

Cod. MT	TAGLIA Size Masse	I (n1:n2)	RPM max n2	Coppia Max Max Torque Max Drehmoment M2 (Nm)	Reversibile 180° 180° Reversible 180° umsetzbar	Lubrificazione int. Coolant through Innenkuehlung Pmax (bar)	Lubr.esterna Ext. coolant Aussenkuehlung	Lav. secco Dry-run Trocken Bearb.	B
DW03120140	C4	1:1	6000	100	X	-	X	X	55.5
DW03120240	C4	1:1	6000	100	X	100 (diag. 2)	X	X	66.5

TAKISAWA

MOD: NX-2500 12ST./15ST. (BMT65)

MODULO MOTORIZZATO ASSIALE MT CAPTO H=95mm

Axial driven tool MT CAPTO H=95mm

Axial angetriebenes Werkzeug MT CAPTO H=95mm

Subject to change without notice.

M.T. srl

Via Casino Albini 480
Tel. 0541/956034-957884
Fax 0541/956341
47842 S. GIOVANNI IN M. (RN)
e-mail: mtma@mtmarchetti.com
<http://www.mtmarchetti.com>



TKW 150-L-42