

ATTENZIONE - ATTENTION - ACHTUNG

- Per lo smontaggio degli utensili utilizzare sempre la chiave di contrasto come indicato nel manuale d'uso.
- For disassembly of the tools use always the contrast key as mentioned in the user instructions.
- Fuer das Abmontieren der Werkzeuge immer den Gegenschlüssel benutzen wie in der Bedienungsanleitung erwaehnt.

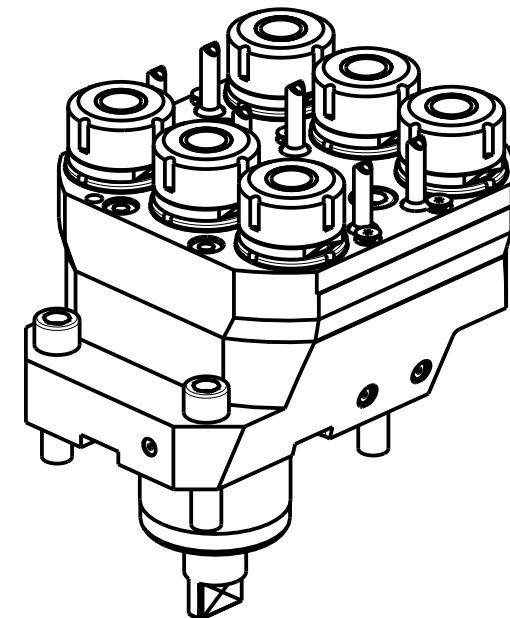

Cod. MT	Mandrino Spindle Spindel	I (n1:n2)	RPM max n2	Coppia Max Max Torque Max Drehmoment M2 (Nm)	N°Utensili N°Tools N°Werkzeuge	Reversibile 180° 180° Reversible 180° umsetzbar	Lubrificazione est. Ext. coolant Aussenkuehlung	Lav. secco Dry-run Trocken Bearb.	CHIAVI INCLUSE Keys included Schluessel inbegriffen
MNL0210625	ER25	1:1	6000	20	6	X	X	X	MNL0210007 MNL0210008

TAKISAWA
 MOD: TS3000/4000/5000 Y/YS 12 ST. (3 KEYS TURRET)
 MODULO MOTORIZZATO RADIALE 6 USCITE
 Radial 6 head driven tool
 Radial angetriebenes Werkzeug 6 Ausgaenge

M.T. srl
 Via Casino Albini 480
 Tel. 0541/956034-957884
 Fax 0541/956341
 47842 S. GIOVANNI IN M. (RN)
 e-mail: mtma@mtmarchetti.com
 http://www.mtmarchetti.com

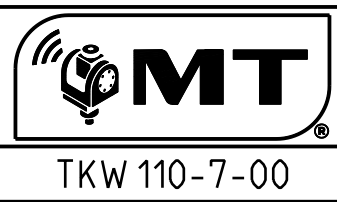

Subject to change without notice.