

**ATTENZIONE - ATTENTION - ACHTUNG**

- Per lo smontaggio degli utensili utilizzare sempre la chiave di contrasto come indicato nel manuale d'uso.
- For disassembly of the tools use always the contrast key as mentioned in the user instructions.
- Fuer das Abmontieren der Werkzeuge immer den Gegenschlüssel benutzen wie in der Bedienungsanleitung erwaehnt.

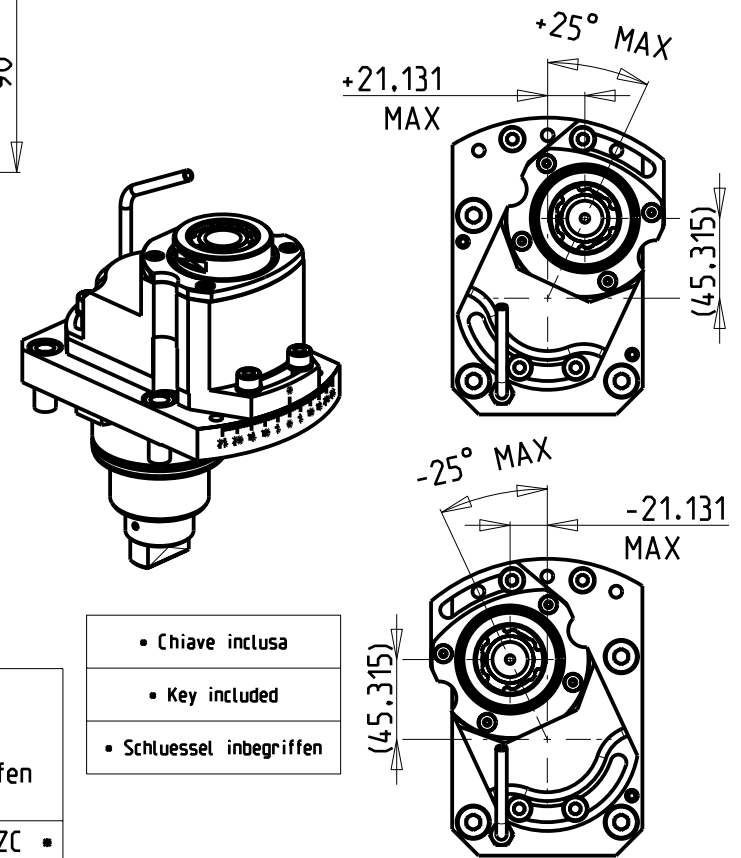

- Chiave inclusa
- Key included
- Schlüssel inbegriffen

Cod. MT	Mandrino Spindle Spindel	I (n1:n2)	RPM max n2	Coppia Max Max Torque Max Drehmoment M2 (Nm)	Reversibile 180° 180° Reversible 180° umsetzbar	Lubrificazione est. Ext. coolant Aussenkuehlung	Lav. secco Dry-run Trocken Bearb.	CHIAVI NON INCLUSE Keys not included Schlüssel nicht einbegriffen		
DW 02980332	ERA32	1:1	6000	100	X	X	X	CHUB30	CHUB50	CHTAER32ZC *

**SMEC (SAMSUNG)**  
 MOD: SL45MC - PL45MC /LY - SLV 80M - SLV800M - PL800VM - SL4500M/Y - SL5500M  
 MODULO MOTORIZZATO RADIALE DISASSATO 50mm ORIENTABILE ±25°  
 Radial ±25° adjustable angle driven tool re-directed by 50mm  
 Radial angetriebenes Werkzeug schwenkbar ±25° achsversetzt um 50mm

**M.T. srl**  
 Via Casino Albini 480  
 Tel. 0541/956034-957884  
 Fax 0541/956341  
 47842 S. GIOVANNI IN M. (RN)  
 e-mail: mtma@mtmarchetti.com  
 http://www.mtmarchetti.com

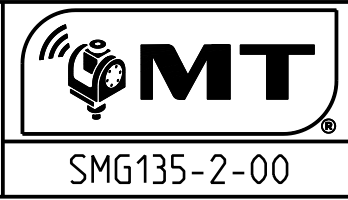

Subject to change without notice.