

D (mm - Inch)	ØMAX (mm)
22 - 1"	89
27 - 32 - 1 1/4" - 1 1/2"	100

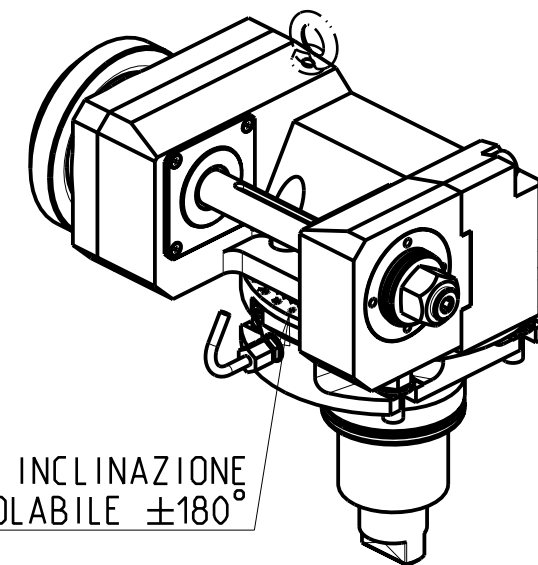

INCLINAZIONE
REGOLABILE ±180°

DOTAZIONI - SUPPLIED WITH - AUSSTATTUNG

mm / inch	
	- N°1 ALBERO + DISTANZIALI
	- N°1 SHAFT + SPACER
	- N°1 DORN + ABSTANDSSTUECK

PER ALBERI E DISTANZIALI VEDI PAG. TBL250-1-00
FOR SHAFT END SPACER SEE PAGE TBL250-1-00
FUER DORN UND ABSTANDSSTUECK SEITE TBL250-1-00

Cod. MT	I (n1:n2)	RPM max n2	Coppia Max Max Torque Max Drehmoment	Lubr.esterna Ext. coolant Aussenkuehlung	Lav. secco Dry-run Trocken Bearb.	D	D	CHIAVI INCLUSE Keys included Schluessel inbegriffen			
			M2 (Nm)			(mm)	(Inch)	CHUB30	CHESL08	CHESL10	CHUB19
DW 00851100	1:1	3000	110	X	X	22-27-32	1"-1 1/4"-1 1/2"	CHUB30	CHESL08	CHESL10	CHUB19
DW 00852100	2:1	1500	130	X	X	22-27-32	1"-1 1/4"-1 1/2"	CHUB30	CHESL08	CHESL10	CHUB19

-LA FUNZIONE DI POLIGONATURA/DENTATURA
DEVE ESSERE INSTALLATA SULLA MACCHINA
-POLYGON CUTTING/GEAR HOBBING FUNCTION
MUST BE INSTALLED ON THE MACHINE
-DIE FUNKTION FÜR POLYGON-BZW.VERZÄHNUNGSFRÄSEN
MUSS AUF DER MASCHINE FREIGESCHALTET WERDEN

SMART

MOD: NL6000/7000 M/LM/SM

MODULO MOTORIZZATO PORTACREATORE (TAGLIA GRANDE)

Driven gear hobber (big size)

Angetriebenes Zahnradwaelzfraes-Werkzeug (grosse version)

Subject to change without notice.

M.T. srl

Via Casino Albini 480
Tel. 0541/956034-957884

Fax 0541/956341

47842 S. GIOVANNI IN M. (RN)

e-mail: mtma@mtmarchetti.com

http://www.mtmarchetti.com



SMA340-4-80