

ATTENZIONE - ATTENTION - ACHTUNG

- Per lo smontaggio degli utensili utilizzare sempre la chiave di contrasto come indicato nel manuale d'uso.
- For disassembly of the tools use always the contrast key as mentioned in the user instructions.
- Fuer das Abmontieren der Werkzeuge immer den Gegenschlüssel benutzen wie in der Bedienungsanleitung erwaeht.

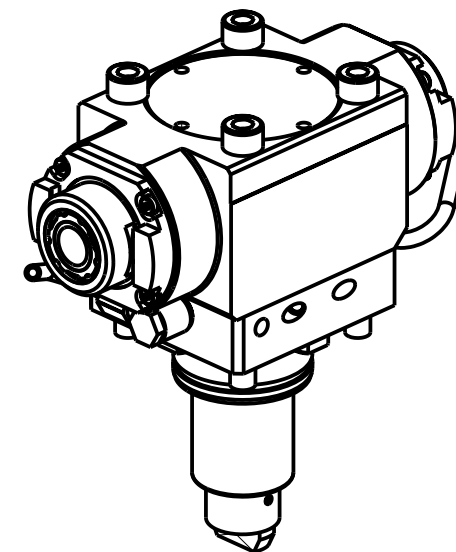
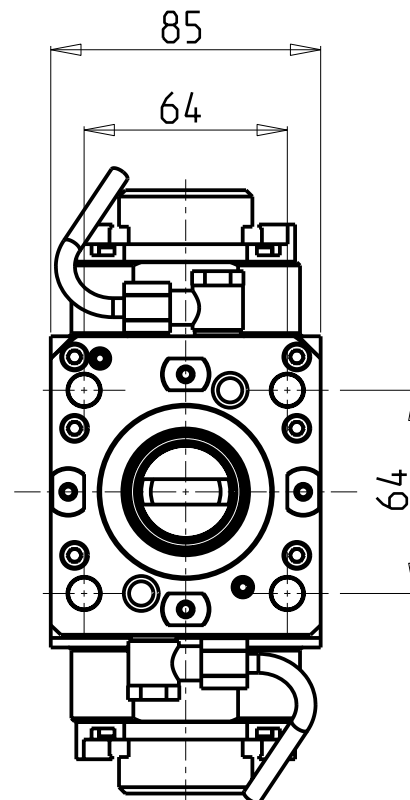
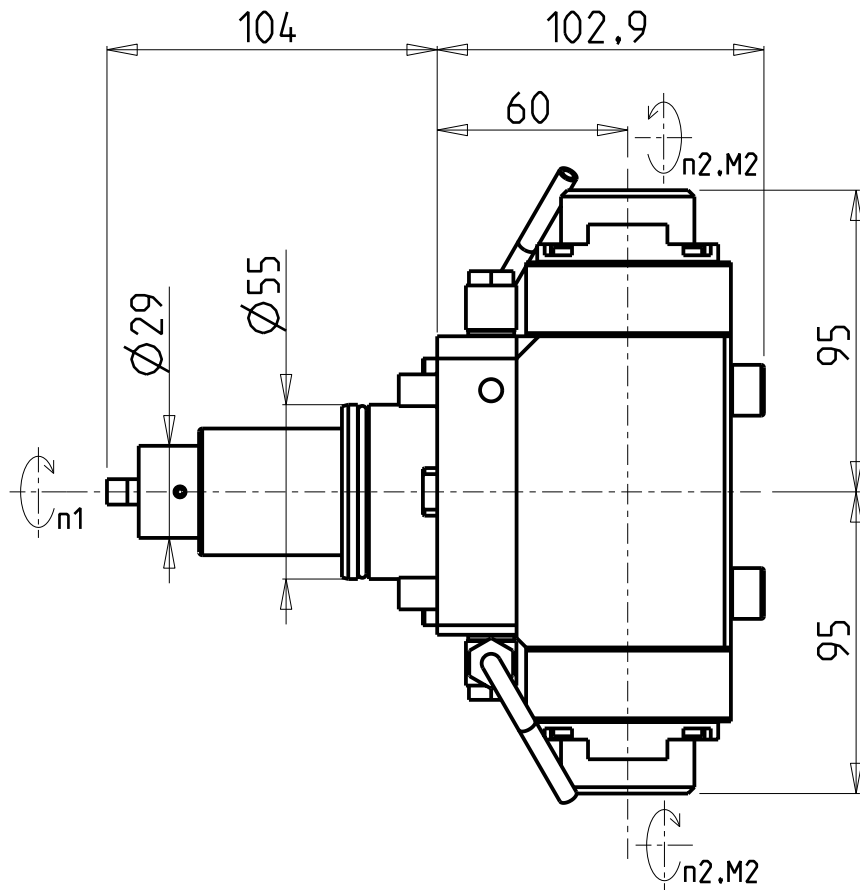

Cod. MT	Mandrino Spindel Spindel	I (n1:n2)	RPM max n2	Coppia Max Max Torque Max Drehmoment M2 (Nm)	Reversibile 180° 180° Reversible 180° umsetzbar	Lubr.esterna Ext. coolant Aussenkuehlung	Lav. secco Dry-run Trocken Bearb.	CHIAVI NON INCLUDE Keys not included Schlüssel nicht einbegriffen		
DW 03930225	ERA25+ERA25	1:2	12000	30	X	X	X	CHUB27	CHTAER25ZC	SAU0070027

- Chiave inclusa
- Key included
- Schlüssel inbegriffen

SMART

MOD: NL1500/2000 M/BM/SY/BSY

MODULO MOTORIZZATO ASSIALE BISPORGENTE MOLTIPLICATO I=1:2 H=60mm

Axial geared-up I=1:2 opposite face twin driven tool H=60mm

Axial angetriebenes Werkzeug halb vorspringend uebersetzt I=1:2 H=60mm

Subject to change without notice.

M.T. srl

Via Casino Albini 480
Tel. 0541/956034-957884
Fax 0541/956341
47842 S. GIOVANNI IN M. (RN)
e-mail: mtma@mtmarchetti.com
http://www.mtmarchetti.com



SMA250-1-10