

INCLINAZIONE
REGOLABILE ±20°

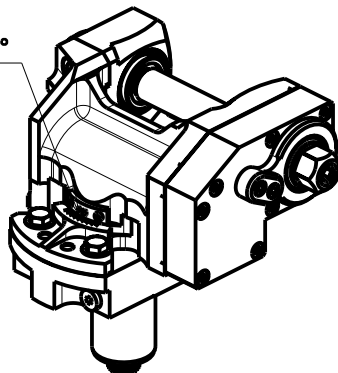

-LA FUNZIONE DI POLIGONATURA/DENTATURA
DEVE ESSERE INSTALLATA SULLA MACCHINA
-POLYGON CUTTING/GEAR HOBBING FUNCTION
MUST BE INSTALLED ON THE MACHINE
-DIE FUNKTION FÜR POLYGON-BZW. VERZÄHNUNGSFRÄSEN
MUSS AUF DER MASCHINE FREIGESCHALTET WERDEN

PER ALBERI E DISTANZIALI VEDI PAG. TBL250-1-00
FOR SHAFT END SPACER SEE PAGE TBL250-1-00
FUER DORN UND ABSTANDSSTUECK SEITE TBL250-1-00

DOTAZIONI - SUPPLIED WITH - AUSSTATTUNG

mm / inch	- N°1 ALBERO + DISTANZIALI
	- N°1 SHAFT + SPACER
	- N°1 DORN + ABSTANDSSTUECK

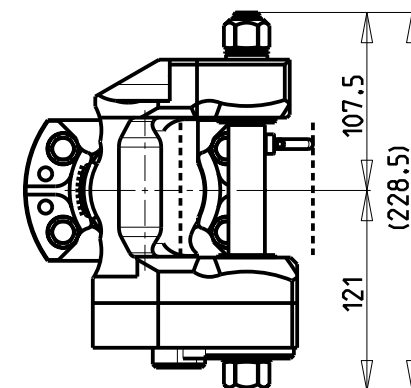

TORRETTE RADIALI
RADIAL TURRETS
RADIAL REVOLVER

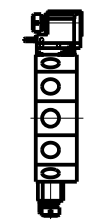

Cod. MT		I (n1:n2)	RPM max n2	Coppia Max Max Torque Max Drehmoment M2 (Nm)	Lubr.esterna Ext. coolant Aussenkuehlung	Lav. secco Dry-run Troekken Bearb.	D (mm)	D (Inch)	CHIAVI INCLUDE Keys included Schlüssel einbegriffen		
versione dx right version version rechts	versione sx left version version links								CHUB24	CHUB13	CHESL08
SAU0051100	SAU0051110	1:1	6000	60	X	X	16-22-27-32	3/4"-1"-1 1/4"	CHUB24	CHUB13	CHESL08
SAU0052100	SAU0052110	2:1	3000	80	X	X	16-22-27-32	3/4"-1"-1 1/4"	CHUB24	CHUB13	CHESL08

SAUTER
VDI 40
MODULO MOTORIZZATO PORTACREATORE VDI40 DIN 5480
Driven gear hobber VDI40 DIN 5480
Angetriebenes Zahnradwaeltzraes-Werkzeug VDI40 DIN 5480

M.T. srl
Via Casino Albini 480
Tel. 0541/956034-957884
Fax 0541/956341
47842 S. GIOVANNI IN M. (RN)
e-mail: mtma@mtmarchetti.com
http://www.mtmarchetti.com



SAU340-3-05

Subject to change without notice.