

versione dx
right version
version rechts

versione sx
left version
version links

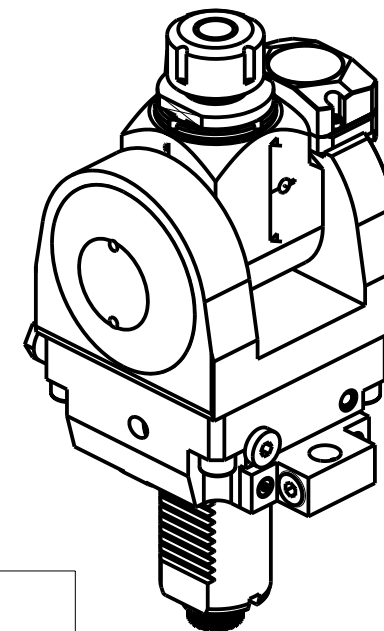
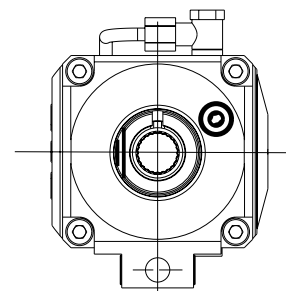
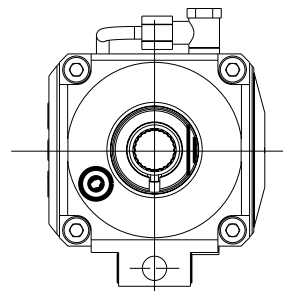

DIN 5480

Cod. MT		Mandrino Spindle Spindel	I (n1:n2)	RPM max n2	Coppia Max Max Torque Max Drehmoment M2 (Nm)	Lubr.esterna Ext. coolant Aussenkuehlung	Lav. secco Dry-run Trocken Bearb.	A	A1	D	L	CHIAVI INCLUSE Keys included Schluessel einbegriffen	
versione dx right version version rechts	versione sx left version version links											CHUB36	CHSTER
SAU0800120	SAU0801120	ER20	1:1	6000	40	X	X	85.16	-	-	-	CHUB36	CHSTER20
SAU0800125	SAU0801125	ER25	1:1	6000	40	X	X	86.16	-	-	-	CHUB36	CHSTER25
SAU0800516	SAU0801516	Ø16x17	1:1	6000	40	X	X	-	65	16	17	CHUB36	CH_VTCROCE_M08
SAU0800522	SAU0801522	Ø22x19	1:1	6000	40	X	X	-	66	22	19	CHUB36	CH_VTCROCE_M10
SAU0800519	SAU0801519	Ø3/4"x3/4"	1:1	6000	40	X	X	-	65	3/4"	3/4"	CHUB36	CH_VTCROCE_M08

SAUTER
VDI 40

MODULO MOTORIZZATO ORIENTABILE ±90° CON NONIO DIGITALE VDI40 DIN 5480
±90° adjustable angle driven tool with digital display VDI40 DIN 5480
Angetriebenes Werkzeug schwenkbar ±90° mit digital display VDI40 DIN 5480

Subject to change without notice.

M.T. srl

Via Casino Albini 480
Tel. 0541/956034-957884
Fax 0541/956341
47842 S. GIOVANNI IN M. (RN)
e-mail: mtma@mtmarchetti.com
http://www.mtmarchetti.com



SAU019-3-61

09/2025