

-LA FUNZIONE DI POLIGONATURA/DENTATURA DEVE ESSERE INSTALLATA SULLA MACCHINA  
 -POLYGON CUTTING/GEAR HOBBING FUNCTION MUST BE INSTALLED ON THE MACHINE  
 -DIE FUNKTION FÜR POLYGON-BZW .VERZÄHNUNGSFRÄSEN MUSS AUF DER MASCHINE FREIGESCHALTET WERDEN

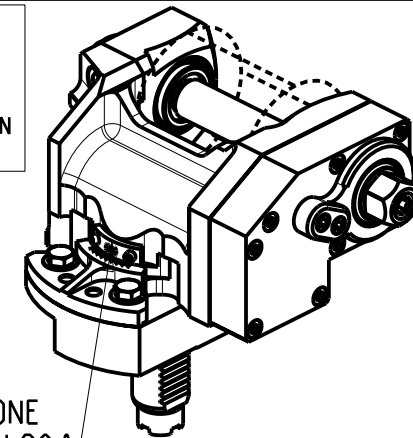

INCLINAZIONE REGOLABILE  $\pm 20^\circ$

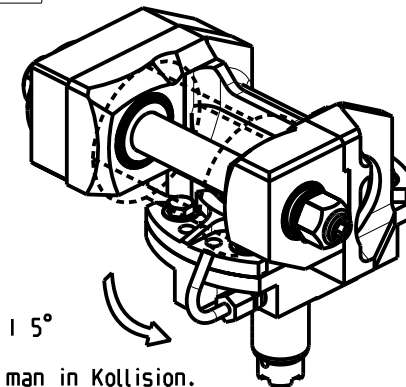

VERSO NEL QUALE OLTRE I  $5^\circ$  SI VA' IN COLLISIONE  
 Gerichtet ueber  $5^\circ$  geht man in Kollision.  
 Directed over  $5^\circ$  it will have a collision.

TORRETTE RADIALI  
 RADIAL TURRETS  
 RADIAL REVOLVER

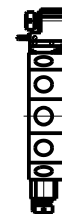

**DOTAZIONI - SUPPLIED WITH - AUSSTATTUNG**

- | mm / inch |                             |
|-----------|-----------------------------|
|           | - N°1 ALBERO + DISTANZIALI  |
|           | - N°1 SHAFT + SPACER        |
|           | - N°1 DORN + ABSTANDSSTUECK |

PER ALBERI E DISTANZIALI VEDI PAG. TBL250-1-00  
 FOR SHAFT END SPACER SEE PAGE TBL250-1-00  
 FUER DORN UND ABSTANDSSTUECK SEITE TBL250-1-00

Cod. MT	I (n1:n2)	RPM max n2	Coppia Max Max Torque Max Drehmoment M2 (Nm)	Lubr.esterna Ext. coolant Aussenkuehlung	Lav. secco Dry-run Trocken Bearb.	B	D (mm)	D (Inch)	CHIAVI INCLUSE Keys included Schluessel inbegriffen		
									CHUB13	CHUB24	CHESL08
OKU0031100	1:1	4000	60	X	X	93	16-22-27-32	3/4"-1"-1 1/4"	CHUB13	CHUB24	CHESL08
OKU0032100	2:1	2000	80	X	X	101	16-22-27-32	3/4"-1"-1 1/4"	CHUB13	CHUB24	CHESL08

OKUMA

MOD: LT200 - LT10M

MODULO MOTORIZZATO PORTACREATORE VD130

Driven gear hobber VD130

Angetriebenes Zahnradwaeltzraes-Werkzeug VD130

Subject to change without notice.

**M.T. srl**

Via Casino Albini 480  
 Tel. 0541/956034-957884  
 Fax 0541/956341

47842 S. GIOVANNI IN M. (RN)  
 e-mail: mtma@tmarchetti.com  
 http://www.tmmarchetti.com



OKU340-1-00

09/2025