

ATTENZIONE - ATTENTION - ACHTUNG

- Per lo smontaggio degli utensili utilizzare sempre la chiave di contrasto come indicato nel manuale d'uso.
- For disassembly of the tools use always the contrast key as mentioned in the user instructions.
- Fuer das Abmontieren der Werkzeuge immer den Gegenschlüssel benutzen wie in der Bedienungsanleitung erwäehnt.

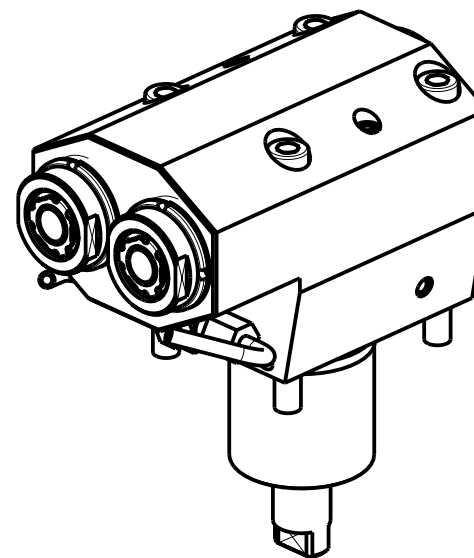

| Cod. MT | Mandrino Spindle Spindel | I (n1:n2) | RPM max n2 | Coppia Max Max Torque Max Drehmoment M2 (Nm) | Reversibile 180° 180° Reversible 180° umsetzbar | Lubrificazione int. Coolant through Innenkuehlung Pmax (bar) | Lubr.esterna Ext. coolant Aussenkuehlung | Lav. secco Dry-run Trocken Bearb. | A | CHIAVI NON INCLUSE Keys not included Schlüssel nicht einbegriffen | | |
|------------|--------------------------|-----------|------------|--|---|--|--|-----------------------------------|-------|---|--------|--------------|
| OKU1010120 | ERA20 | 1:1 | 6000 | 30 | X | - | X | X | 109.5 | CHUB22 | CHUB36 | CHTAER20ZC ■ |
| OKU1010220 | ERA20 | 1:1 | 6000 | 30 | X | 70 | X | - | 118 | CHUB22 | CHUB36 | CHTAER20ZC ■ |

- Chiave inclusa
- Key included
- Schlüssel inbegriffen

OKUMA
MOD: LT2000EX 16ST.

MODULO MOTORIZZATO ASSIALE 2 USCITE IN Y
Axial single side twin head driven tool in Y
Axial angetriebenes Werkzeug 2 Ausgänge in Y

Subject to change without notice.

M.T. srl

Via Casino Albini 480
Tel. 0541/956034-957884
Fax 0541/956341
47842 S. GIOVANNI IN M. (RN)
e-mail: mtma@mtmarchetti.com
http://www.mtmarchetti.com



OKU260-6-10