

ATTENZIONE - ATTENTION - ACHTUNG

- Per lo smontaggio degli utensili utilizzare sempre la chiave di contrasto come indicato nel manuale d'uso.
- For disassembly of the tools use always the contrast key as mentioned in the user instructions.
- Fuer das Abmontieren der Werkzeuge immer den Gegenschlüssel benutzen wie in der Bedienungsanleitung erwaeht.

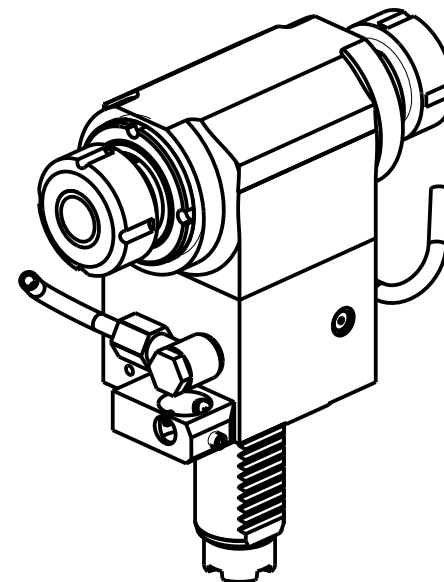

- Chiave inclusa
- Key included
- Schluessel inbegriffen

Cod. MT	Mandrino Spindle Spindel	I (n1:n2)	RPM max n2	Coppia Max Max Torque Max Drehmoment M2 (Nm)	Lubr.esterna Ext. coolant Aussenkuehlung	Lav. secco Dry-run Trocken Bearb.	A	B	CHIAVI NON INCLUDE Keys not included Schluessel nicht einbegriffen		
OKU1730220	ER20+ER20	1:1	6000	32	X	X	81.2	82.2	-	CHUB38	CHSTER20
OKU1730225	ER25+ER25	1:1	6000	32	X	X	77.2	83.2	CHUB29	CHUB36	CHSTER25
OKU1730320	ERA20+ERA20	1:1	6000	32	X	X	68.5	66.5	CHUB22	CHUB36	CHTAER20ZC *

OKUMA
MOD: LT200 - LT10M

MODULO MOTORIZZATO RADIALE BISPORGENTE VD130 H=90mm
Radial opposite face twin driven tool VD130 H=90mm
Radial angetriebenes Werkzeug halb vorspringend VD130 H=90mm

Subject to change without notice.

M.T. srl
Via Casino Albini 480
Tel. 0541/956034-957884
Fax 0541/956341
47842 S. GIOVANNI IN M. (RN)
e-mail: mtma@mtmarchetti.com
http://www.mtmarchetti.com



OKU240-1-20