

### ATTENZIONE - ATTENTION - ACHTUNG

- Per lo smontaggio degli utensili utilizzare sempre la chiave di contrasto come indicato nel manuale d'uso.
- For disassembly of the tools use always the contrast key as mentioned in the user instructions.
- Fuer das Abmontieren der Werkzeuge immer den Gegenschlüssel benutzen wie in der Bedienungsanleitung erwäohnt.

### ATTENZIONE - ATTENTION - ACHTUNG

- PRIMA DI UTILIZZARE IL MOTORIZZATO CONSULTARE LE ISTRUZIONI ALLEGATE!
- BEFORE USING THE DRIVEN TOOL, PLEASE CHECK THE ENCLOSED INSTRUCTION SHEET!
- VOR DER BENUTZUNG DES ANGETRIEBENEN WERKZEUGES, DIE BEILIEGENDEN INSTRUKTIONEN DURCHLESEN!

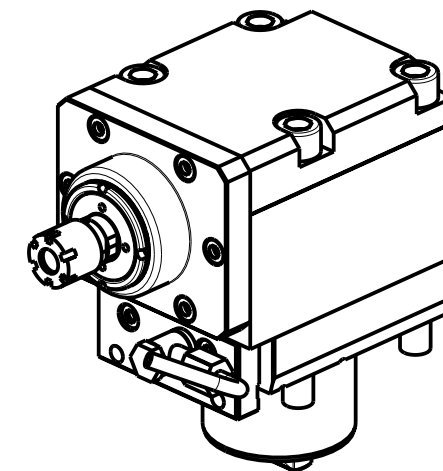

Cod. MT	Mandrino Spindle Spindel	I (n1:n2)	RPM max n2	Coppia Max Max Torque Max Drehmoment M2 (Nm)	Reversibile 180° 180° Reversible 180° umsetzbar	Lubrificazione int. Coolant through Innenkuehlung Pmax (bar)	Lubr.esterna Ext. coolant Aussenkuehlung	Lav. secco Dry-run Trocken Bearb.	L2	CHIAVI INCLUDE Keys included Schluessel einbegriffen	
										CHUB17	CHMNER16
OKU0410116	ER16	1:3	18000	10	X	-	X	-	53	CHUB17	CHMNER16
OKU0410216	ER16	1:3	18000	10	X	70	X	-	63	CHUB17	CHMNER16

**OKUMA**  
 MOD: LB2000-2500-3000EX(I) M/MY/MW/MYW - LB2000-2500-3000EX(II) M/MY/MW/MYW - LB3000EX(III) M/MY/MW/MYW  
 LU3000EX M/MY/MW - GENOS L300MW/MYW - GENOS L3000e M/MY

MODULO MOTORIZZATO ASSIALE MOLTIPLICATO I=1:3  
 Axial geared-up I=1:3 driven tool  
 Axial angetriebenes Werkzeug uebersetzt I=1:3

**M.T. srl**  
 Via Casino Albini 480  
 Tel. 0541/956034-957884  
 Fax 0541/956341  
 47842 S. GIOVANNI IN M. (RN)  
 e-mail: mtma@mtmarchetti.com  
 http://www.mtmarchetti.com



OKU205-4-10

Subject to change without notice.

09/2025