

**ATTENZIONE - ATTENTION - ACHTUNG**

- Per lo smontaggio degli utensili utilizzare sempre la chiave di contrasto come indicato nel manuale d'uso.
- For disassembly of the tools use always the contrast key as mentioned in the user instructions.
- Fuer das Abmontieren der Werkzeuge immer den Gegenschlüssel benutzen wie in der Bedienungsanleitung erwaeht.

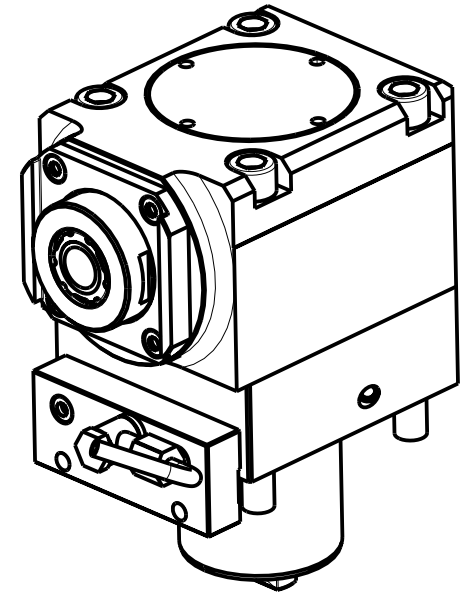

- Chiave inclusa
- Key included
- Schlüssel inbegriffen

Cod. MT	Mandrino Spindle Spindel	I (n1:n2)	RPM max n2	Coppia Max Max Torque Max Drehmoment M2 (Nm)	Reversibile 180° 180° Reversible 180° umsetzbar	Lubrificazione int. Coolant through Innenkuehlung Pmax (bar)	Lubr.esterna Ext. coolant Aussenkuehlung	Lav. secco Dry-run Trocken Bearb.	B	CHIAVI NON INCLUDE Keys not included Schlüssel nicht einbegriffen		
OKU0470325	ERA25	1:2	12000	50	X	-	X	X	64	CHUB27	CHTAER25ZC	OKU0650004
OKU0470425	ERA25	1:2	12000	50	X	100 (diag. 2)	X	X	74	CHUB27	CHTAER25ZC	OKU0650004

**OKUMA**  
 MOD: LB4000EX(I) - LB4000EX(II) - LB4000EX(III) - LU4000EX  
 MODULO MOTORIZZATO ASSIALE MOLTIPLICATO I=1:2  
 Axial geared-up I=1:2 driven tool  
 Axial angetriebenes Werkzeug uebersetzt I=1:2

**M.T. srl**  
 Via Casino Albini 480  
 Tel. 0541/956034-957884  
 Fax 0541/956341  
 47842 S. GIOVANNI IN M. (RN)  
 e-mail: mtma@mtmarchetti.com  
 http://www.mtmarchetti.com



**OKU200-5-10**

Subject to change without notice.