

### ATTENZIONE - ATTENTION - ACHTUNG

- Per lo smontaggio degli utensili utilizzare sempre la chiave di contrasto come indicato nel manuale d'uso.
- For disassembly of the tools use always the contrast key as mentioned in the user instructions.
- Fuer das Abmontieren der Werkzeuge immer den Gegenschlüssel benutzen wie in der Bedienungsanleitung erwäehnt.

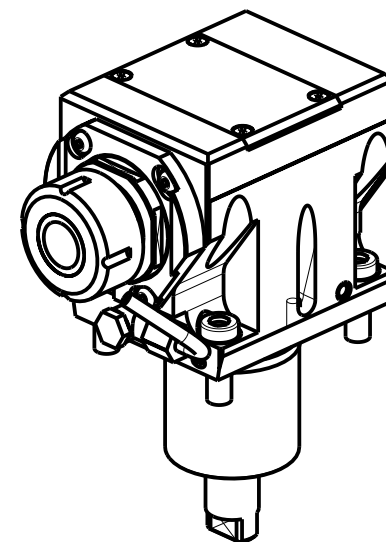

Cod. MT	Mandrino Spindle Spindel	I (n1:n2)	RPM max n2	Coppia Max Max Torque Max Drehmoment M2 (Nm)	Reversibile 180° 180° Reversible 180° umsetzbar	Lubrificazione int. Coolant through Innenkuehlung Pmax (bar)	Lubr.esterna Ext. coolant Aussenkuehlung	Lav. secco Dry-run Trocken Bearb.	B	CHIAVI NON INCLUDE Keys not included Schluessel nicht einbegriffen	
OKU0980132	ER32	2:1	3000	90	X	-	X	X	54	CHSTER32	OKU0650004 ■
OKU0980232	ER32	2:1	3000	90	X	100 (diag. 2)	X	X	65	CHSTER32	OKU0650004 ■

- Chiave inclusa
- Key included
- Schluessel inbegriffen

OKUMA  
MOD: LT2000EX 16ST.

MODULO MOTORIZZATO ASSIALE RIDOTTO I=2:1  
Axial geared-down I=2:1 driven tool  
Axial angetriebenes Werkzeug untersetzt I=2:1

Subject to change without notice.

**M.T. srl**

Via Casino Albini 480  
Tel. 0541/956034-957884  
Fax 0541/956341  
47842 S. GIOVANNI IN M. (RN)  
e-mail: mtma@mtmarchetti.com  
http://www.mtmarchetti.com



OKU190-6-10