

ATTENZIONE - ATTENTION - ACHTUNG

- Per lo smontaggio degli utensili utilizzare sempre la chiave di contrasto come indicato nel manuale d'uso.
- For disassembly of the tools use always the contrast key as mentioned in the user instructions.
- Fuer das Abmontieren der Werkzeuge immer den Gegenschlüssel benutzen wie in der Bedienungsanleitung erwaehnt.

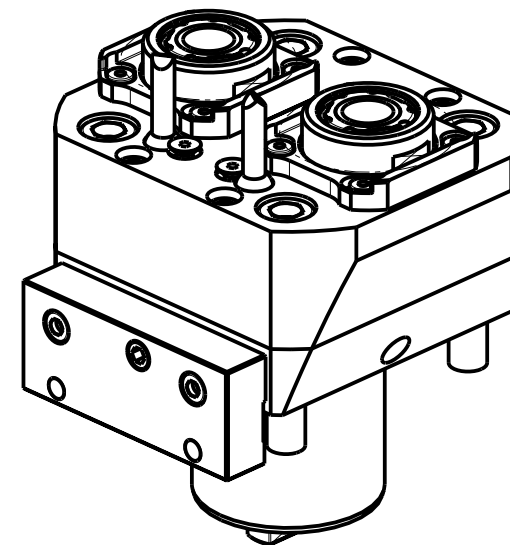

Cod. MT	Mandrino Spindle Spindel	I (n1:n2)	RPM max n2	Coppia Max Max Torque Max Drehmoment	Lubrificazione int. Coolant through Innenkuehlung	Lubr.esterna Ext. coolant Aussenkuehlung	Lav. secco Dry-run Trocken Bearb.	CHIAVI NON INCLUSE Keys not included Schlüssel nicht einbegriffen		
				M2 (Nm)	Pmax (bar)					
OKU0450125	ERA25	1:1	6000	40	-	X	X	CHUB27	CHTAER25ZC	OKU0290009
OKU0450225	ERA25	1:1	6000	40	70	X	-	CHUB27	CHTAER25ZC	OKU0290009

- Chiave inclusa
- Key included
- Schlüssel inbegriffen

OKUMA
MOD: LB4000EX(I) - LB4000EX(II) - LB4000EX(III) - LU4000EX

MODULO MOTORIZZATO RADIALE 2 USCITE IN Y
Radial single side twin head driven tool in Y
Radial angetriebenes Werkzeug 2 Ausgaenge in Y

Subject to change without notice.

M.T. srl
Via Casino Albini 480
Tel. 0541/956034-957884
Fax 0541/956341
47842 S. GIOVANNI IN M. (RN)
e-mail: mtma@mtmarchetti.com
http://www.mtmarchetti.com



OKU080-5-00