

ATTENZIONE - ATTENTION - ACHTUNG

- Per lo smontaggio degli utensili utilizzare sempre la chiave di contrasto come indicato nel manuale d'uso.
- For disassembly of the tools use always the contrast key as mentioned in the user instructions.
- Fuer das Abmontieren der Werkzeuge immer den Gegenschlüssel benutzen wie in der Bedienungsanleitung erwaeht.

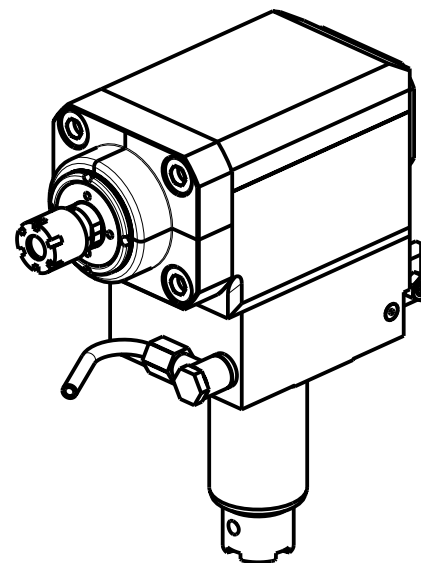

**TORRETTE ASSIALI
AXIAL TURRETS
AXIAL REVOLVER**

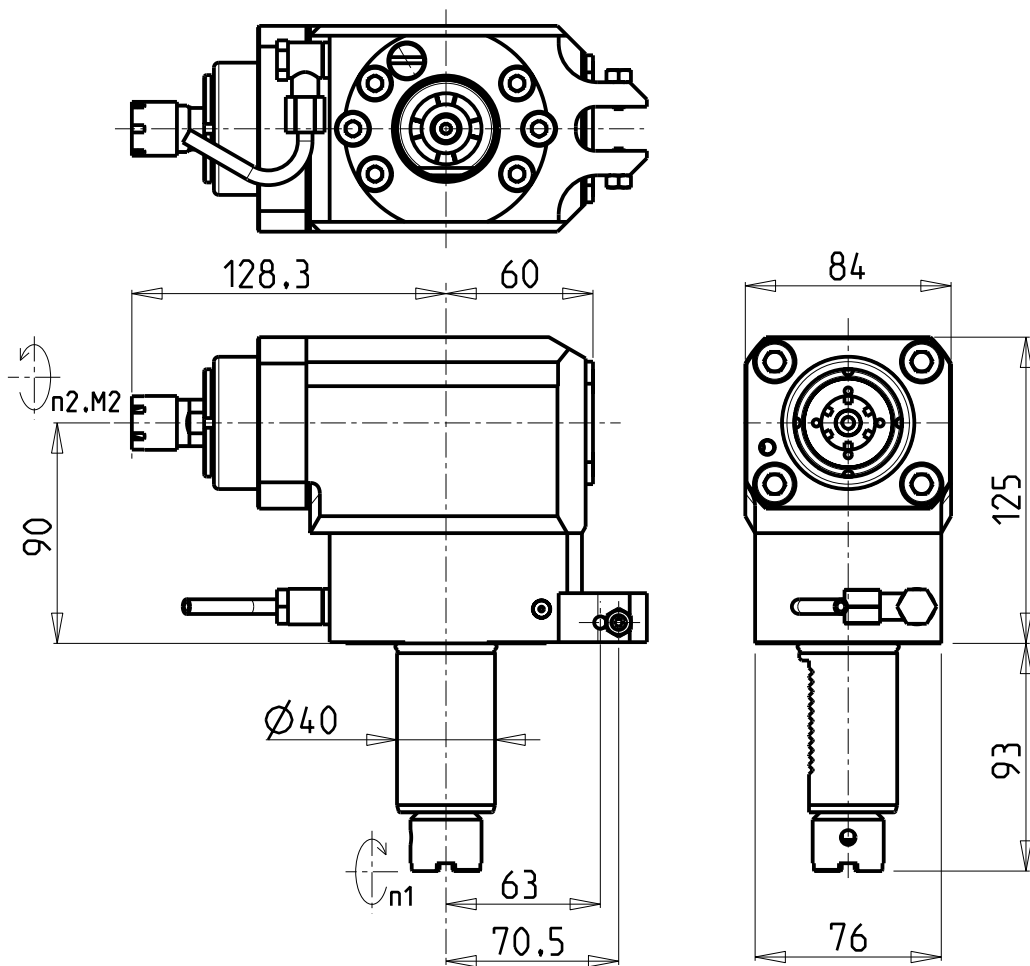
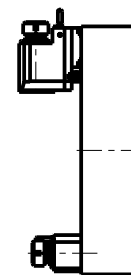

Cod. MT	Mandrino Spindle Spindel	I (n1:n2)	RPM max n2	Coppia Max Max Torque Max Drehmoment M2 [Nm]	Lubr.esterna Ext. coolant Aussenkuehlung	Lav. secco Dry-run Trocken Bearb.	CHIAVI INCLUSE Keys included Schluessel einbegriffen
OKU1300016	ER16	1:3	12000	10	X	-	CHUB17 CHMNER16

OKUMA
 MOD: LB15/300 - LT15/300 - LR15 - LU15M - LU300M - GENOSL300M - GENOS L3000e M/MY (VDI40) - ES L10M

MODULO MOTORIZZATO RADIALE MOLTIPLICATO I=1:3 VDI40 H=90mm
 Radial geared-up I=1:3 driven tool VDI40 H=90mm
 Radial angetriebenes Werkzeug uebersetzt I=1:3 VDI40 H=90mm

M.T. srl
 Via Casino Albini 480
 Tel. 0541/956034-957884
 Fax 0541/956341
 47842 S. GIOVANNI IN M. (RN)
 e-mail: mtma@mtmarchetti.com
 http://www.mtmarchetti.com



OKU018-2-24

Subject to change without notice.

09/2025