

ATTENZIONE - ATTENTION - ACHTUNG

- Per lo smontaggio degli utensili utilizzare sempre la chiave di contrasto come indicato nel manuale d'uso.
- For disassembly of the tools use always the contrast key as mentioned in the user instructions.
- Fuer das Abmontieren der Werkzeuge immer den Gegenschlüssel benutzen wie in der Bedienungsanleitung erwaeht.

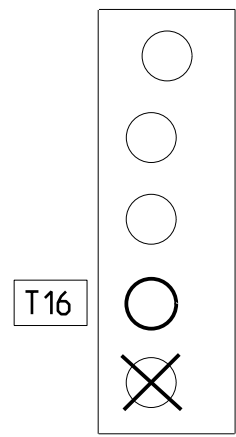
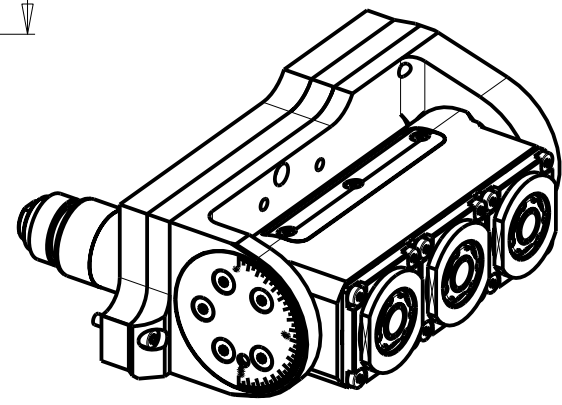

Cod. MT	Mandrino Spindle Spindel	I (n1:n2)	RPM max n2	Lubr.esterna Ext. coolant Aussekkuehlung	Lav. secco Dry-run Trocken Bearb.	CHIAVI INCLUSE Keys included Schluessel inbegriffen		
NMR0040316	ERA16	1:1	6000	X	X	NMR0040012	CHUB19_SP3	CHTAER16ZC

NOMURA
 MOD: NN20J - NN20J2 - NN20JS
 MODULO MOTORIZZATO ORIENTABILE TRIPLO ±90°
 ±90° triple adjustable angle driven tool
 Dreifach-Angetriebenes Werkzeug schwenkbar ±90°

M.T. srl
 Via Casino Albini 480
 Tel. 0541/956034-957884
 Fax 0541/956341
 47842 S. GIOVANNI IN M. (RN)
 e-mail: mtma@mtmarchetti.com
 http://www.mtmarchetti.com



NOM338-1-20

Subject to change without notice.