

ATTENZIONE - ATTENTION - ACHTUNG

- FUORI VOLTEGGIO!
- OUT OF MAXIMUM SWING!
- WERKZEUG AUSSER INTERFERENZ!

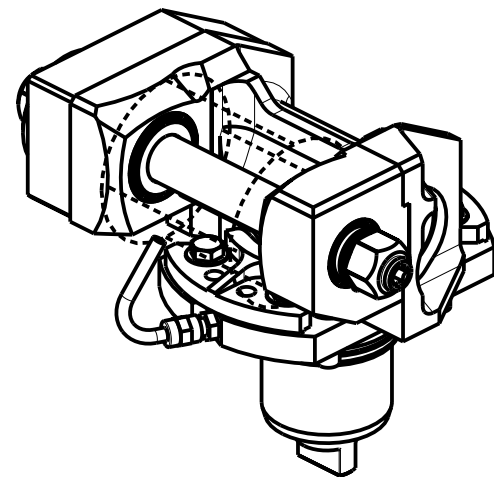

DOTAZIONI - SUPPLIED WITH - AUSSTATTUNG

- | mm / inch | |
|-----------|-----------------------------|
| | - N°1 ALBERO + DISTANZIALI |
| | - N°1 SHAFT + SPACER |
| | - N°1 DORN + ABSTANDSSTUECK |

PER ALBERI E DISTANZIALI VEDI PAG. TBL250-1-00
 FOR SHAFT END SPACER SEE PAGE TBL250-1-00
 FUER DORN UND ABSTANDSSTUECK SEITE TBL250-1-00

-LA FUNZIONE DI POLIGONATURA/DENTATURA DEVE ESSERE INSTALLATA SULLA MACCHINA
 -POLYGON CUTTING/GEAR HOBBING FUNCTION MUST BE INSTALLED ON THE MACHINE
 -DIE FUNKTION FÜR POLYGON-BZW. VERZÄHNUNGSFRÄSEN MUSS AUF DER MASCHINE FREIGESCHALTET WERDEN

Cod. MT	I (n1:n2)	RPM max n2	Coppia Max Max Torque Max Drehmoment M2 (Nm)	Reversibile 180° 180° Reversible 180° umsetzbar	Lubrificazione est. Ext. coolant Aussenkuehlung	Lav. secco Dry-run Trocken Bearb.	D (mm)	D (Inch)	CHIAVI INCLUSE Keys included Schlüssel inbegriffen			
									CHUB13	CHUB24	CHESL08	CHESL07
NKM0331100	1:1	6000	60	X	X	X	16-22-27-32	3/4"-1"-1 1/4"	CHUB13	CHUB24	CHESL08	CHESL07
NKM0332100	2:1	3000	80	X	X	X	16-22-27-32	3/4"-1"-1 1/4"	CHUB13	CHUB24	CHESL08	CHESL07

NAKAMURA-TOME

MOD: Super Mill WT150/WT15011/WY250/SC200L - SUPER NTY3 JUMBO

MODULO MOTORIZZATO PORTACREATORE

Driven gear hobber

Angetriebenes Zahnradwaeltzfraes-Werkzeug

Subject to change without notice.

M.T. srl
 Via Casino Albini 480
 Tel. 0541/956034-957884
 Fax 0541/956341
 47842 S. GIOVANNI IN M. (RN)
 e-mail: mtma@mtmarchetti.com
 http://www.mtmarchetti.com



NKM340-4-00