

- Chiave inclusa
- Key included
- Schluessel inbegriffen

### ATTENZIONE - ATTENTION - ACHTUNG

- Per lo smontaggio degli utensili utilizzare sempre la chiave di contrasto come indicato nel manuale d'uso.
- For disassembly of the tools use always the contrast key as mentioned in the user instructions.
- Fuer das Abmontieren der Werkzeuge immer den Gegenschluesel benutzen wie in der Bedienungsanleitung erwaehnt.

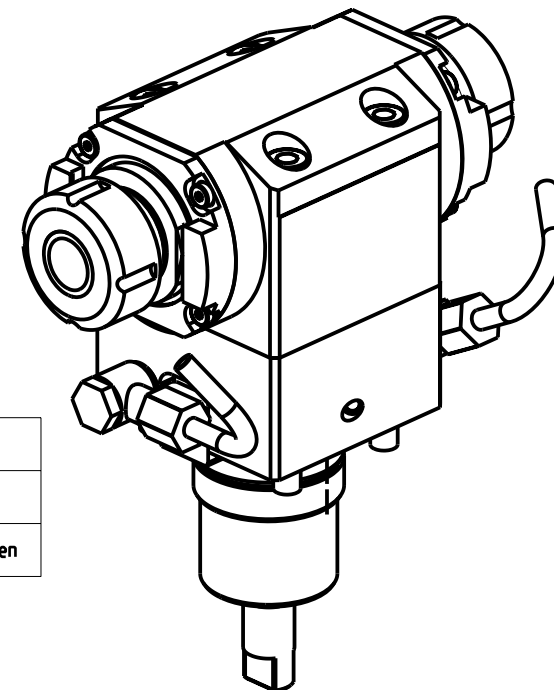

Cod. MT	Mandrino Spindle Spindel	I (n1:n2)	RPM max n2	Coppia Max Max Torque Max Drehmoment M2 (Nm)	Reversibile 180° 180° Reversible 180° umsetzbar	Lubrificazione est. Ext. coolant Aussenkuehlung	Lav. secco Dry-run Trocken Bearb.	CHIAVI NON INCLUSE Keys not included Schluessel nicht einbegriffen	
NKM1800225	ER25+ER25	1:1	6000	35	X	X	X	CHSTER25	OKU0290009 *

NAKAMURA-TOME

MOD: NTJ100 - SC100 - SC100X<sup>2</sup> - MX100

MODULO MOTORIZZATO ASSIALE BISPORGENTE H=75mm

Axial opposite face twin driven tool H=75mm

Axial angetriebenes Werkzeug halb vorspringend H=75mm

Subject to change without notice.

**M.T. srl**

Via Casino Albini 480  
Tel. 0541/956034-957884  
Fax 0541/956341  
47842 S. GIOVANNI IN M. (RN)  
e-mail: mtma@mtmarchetti.com  
http://www.mtmarchetti.com



NKM240-1-20