

**ATTENZIONE - ATTENTION - ACHTUNG**

- VERIFICARE LE MISURE DI INGOMBRO PER POSSIBILE INTERFERENZA SU ALCUNI MODELLI DI MACCHINE
- Please check the overall sizes for possible interferences on some machine models
- Bitte überprüfen sie das ausmass um mögliche interferenzen auf einigen maschinen modellen zu vermeiden

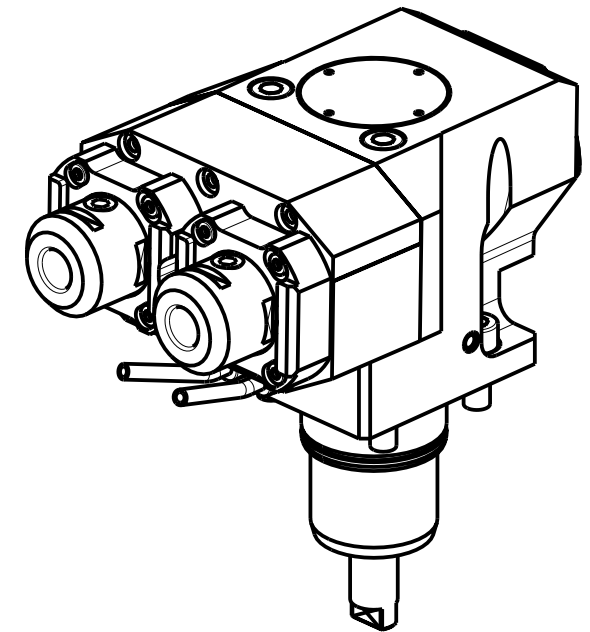
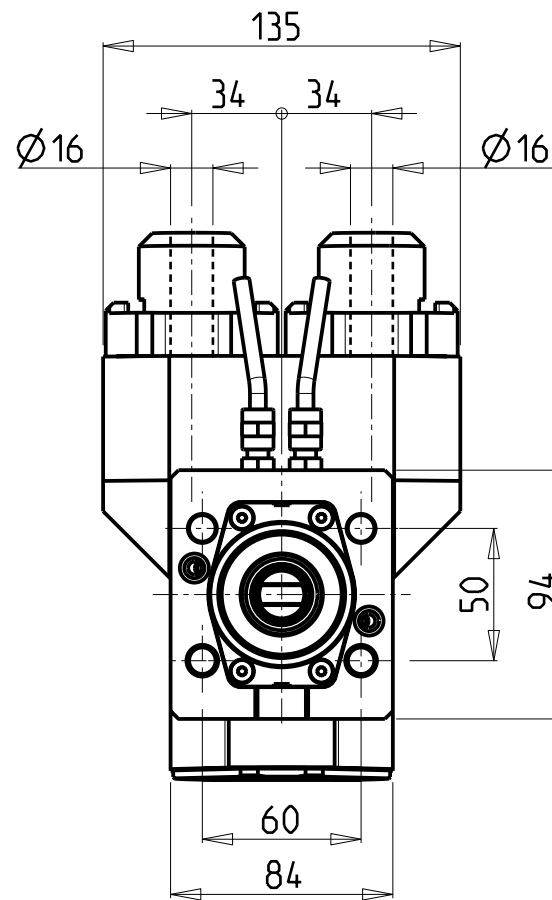
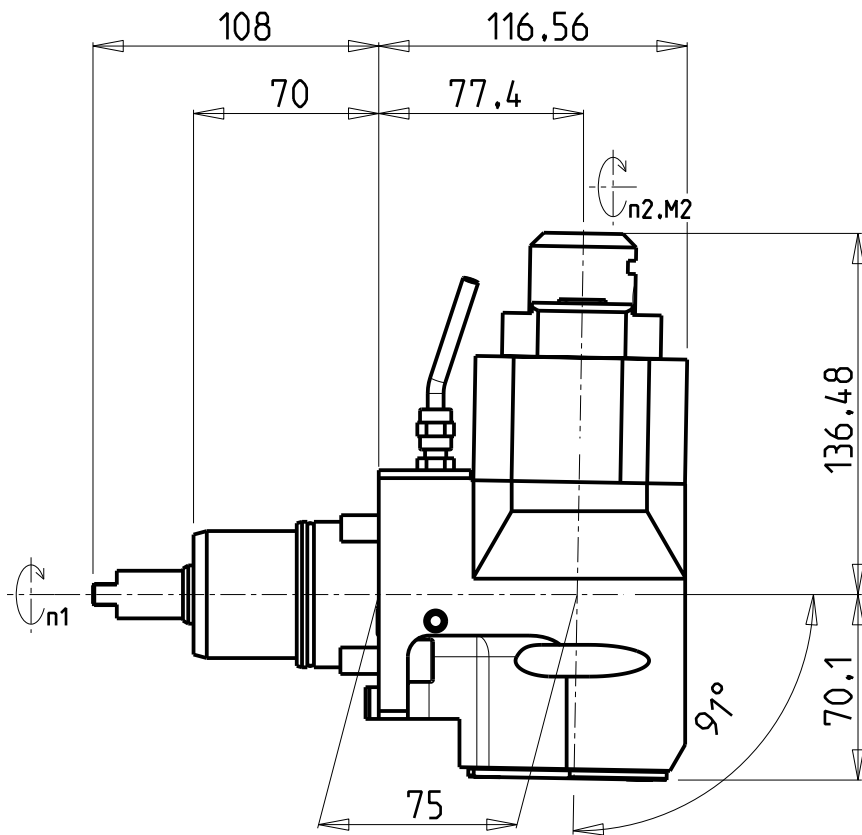

Cod. MT	Mandrino Spindle Spindel	I (n1:n2)	RPM max n2	Coppia Max Max Torque Max Drehmoment M2 [Nm]	Reversibile 180° 180° Reversible 180° umsetzbar	Lubr.esterna Ext. coolant Aussenkuehlung	Lav. secco Dry-run Trocken Bearb.	CHIAVI INCLUSE Keys included Schlüssel inbegriffen
NKM1250616	WELDON 16	1:1	6000	30	X	X	X	SAU0070027

**NAKAMURA-TOME**

WT250 - WTW150 - WTS150 - SC150/200/250 - SC200II 12/16 ST. - SC300II 16ST. - JX200/250 - SUPER NTJX - AS200 15ST. - AS200L 15ST.

MODULO MOTORIZZATO ASSIALE 2 USCITE IN Y PER POLIGONATURA INTERNA H=75mm  
 Axial single side twin head driven tool in Y for internal polygon-making H=75mm  
 Axial angetriebenes Werkzeug 2 Ausgänge in Y fuer interne Facettierung H=75mm

Subject to change without notice.

**M.T. srl**

Via Casino Albini 480  
 Tel. 0541/956034-957884  
 Fax 0541/956341  
 47842 S. GIOVANNI IN M. (RN)  
 e-mail: mtma@mtmarchetti.com  
 http://www.mtmarchetti.com



NKM233-2-10