

ATTENZIONE - ATTENTION - ACHTUNG

- VERIFICARE LE MISURE DI INGOMBRO PER POSSIBILE INTERFERENZA SU ALCUNI MODELLI DI MACCHINE
- Please check the overall sizes for possible interferences on some machine models
- Bitte überprüfen sie das ausmass um mögliche interferenzen auf einigen maschinen modellen zu vermeiden

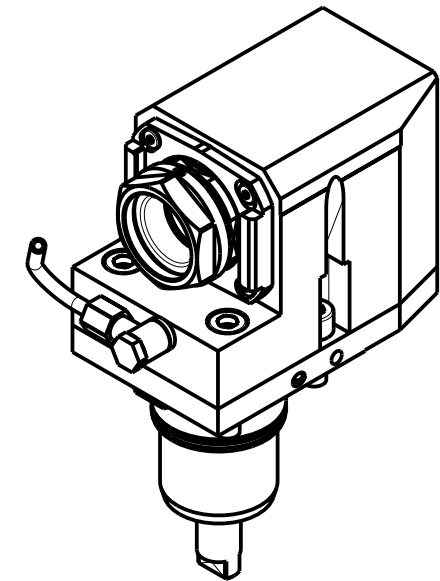

PER PORTAUTENSILI MODULARI MTSK-40 VEDI PAG. TBL300-1-40
 FOR MTSK-40 QUICK CHANGE TOOLHOLDERS CLAMPINGS SEE PAGE TBL300-1-40
 FUER MTSK-40 MODULARE WERKZEUGAUFNAHMEN SIEHE SEITE TBL300-1-40

Cod. MT	Mandrino Spindle Spindel	I (n1:n2)	RPM max n2	Coppia Max Max Torque Max Drehmoment M2 (Nm)	Reversibile 180° 180° Reversible 180° umsetzbar	Lubrificazione int. Coolant through Innenkuehlung Pmax (bar)	Lubr.esterna Ext. coolant Aussenkuehlung	Lav. secco Dry-run Trocken Bearb.	B	CHIAVI NON INCLUDE Keys not included Schluessel nicht einbegriffen	
NKM114.0140	MTSK-40	1:1	6000	50	X	-	X	X	95	CHUB46	MNZO410005 ■
NKM114.0240	MTSK-40	1:1	6000	50	X	70	X	-	108.5	CHUB46	MNZO410005 ■

- Chiave inclusa
- Key included
- Schluessel inbegriffen

NAKAMURA-TOME

WT250 - WT15011/25011 - WTW150 - WTS150 - SC150/200/250 - SC20011 12/16 ST. - SC30011 16ST. - JX200/250
 SUPER NTJX - NTY3 150(V)/250 - AS200L 15ST.

MODULO MOTORIZZATO ASSIALE ARRETRATO MTSK H=75mm
 Axial MTSK rear-set driven tool H=75mm
 Axial MTSK angetriebenes Werkzeug zurueckversetzt H=75mm

M.T. srl

Via Casino Albini 480
 Tel. 0541/956034-957884
 Fax 0541/956341
 47842 S. GIOVANNI IN M. (RN)
 e-mail: mtma@mtmarchetti.com
 http://www.mtmarchetti.com



NKM180-2-10-K

Subject to change without notice.

03/2026