

CUSCINETTI MAGGIORATI PER LAVORAZIONI PESANTI

Reinforced bearings for
heavy machining

Vergroesserte Lager fuer
schwerere Bearbeitungen

ATTENZIONE - ATTENTION - ACHTUNG

- Per lo smontaggio degli utensili utilizzare sempre la chiave di contrasto come indicato nel manuale d'uso.
- For disassembly of the tools use always the contrast key as mentioned in the user instructions.
- Fuer das Abmontieren der Werkzeuge immer den Gegenschlüssel benutzen wie in der Bedienungsanleitung erwaeht.

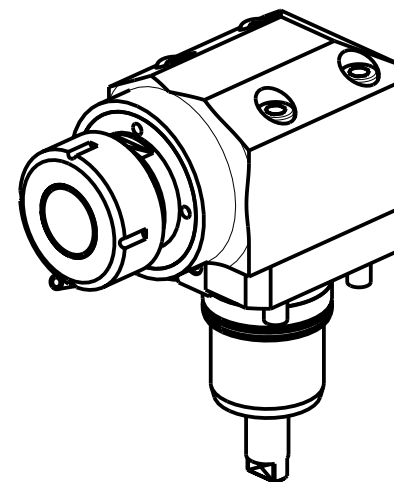

- Chiave inclusa
- Key included
- Schluessel inbegriffen

Cod. MT	Mandrino Spindel	I (n1:n2)	RPM max n2	Coppia Max Max Torque Max Drehmoment M2 (Nm)	Reversibile 180° 180° Reversible 180° umsetzbar	Lubrificazione int. Coolant through Innenkuehlung Pmax (bar)	Lubrificazione est. Ext. coolant Aussenkuehlung	Lav. secco Dry-run Trocken Bearb.	A	B	A1	ØD	L	CHIAVI NON INCLUDE Keys not included Schluessel nicht einbegriffen	
NKM0070140	ER40	1:1	6000	50	X	-	X	X	119.16	48	-	-	-	CHUB46	CHSTER40
NKM0070240	ER40	1:1	6000	50	X	100 (diag. 2)	X	X	119.16	58	-	-	-	CHUB46	CHSTER40
NKM0072519	Ø1" x19	1:1	6000	50	X	-	X	X	-	48	91.5	1"	19	CHUB46	CH_VTCROCE_M12 ▪
NKM0072721	Ø27x21	1:1	6000	50	X	-	X	X	-	48	91.5	27	20	CHUB36	CH_VTCROCE_M12 ▪

NAKAMURA-TOME

WT150/250 - WT15011/25011 - WTW150 - WTS150 - SUPER NTM3 - SUPER NTJ - SC150/200/250 - SC20011 12/16 ST.
SC30011 16ST. - NTY3 150(V)/250 - TW10M/MY/MM/MMY/MMYY-TW20M/MY/MM/MMY/MMYY 16ST. - WY 150(V)/250 - AS200 15/12 ST. - AS200L 15/12 ST.

MODULO MOTORIZZATO ASSIALE MAGGIORATO H=55mm

Axial reinforced driven tool H=55mm

Axial angetriebenes Werkzeug vergroessert H=55mm

Subject to change without notice.

M.T. srl

Via Casio Albini 480
Tel. 0541/956034-957884
Fax 0541/956341
47842 S. GIOVANNI IN M. (RN)
e-mail: mtma@mtmarchetti.com
http://www.mtmarchetti.com



NKM170-2-10