

ATTENZIONE - ATTENTION - ACHTUNG

- Per lo smontaggio degli utensili utilizzare sempre la chiave di contrasto come indicato nel manuale d'uso.
- For disassembly of the tools use always the contrast key as mentioned in the user instructions.
- Fuer das Abmontieren der Werkzeuge immer den Gegenschlüssel benutzen wie in der Bedienungsanleitung erwaeht.

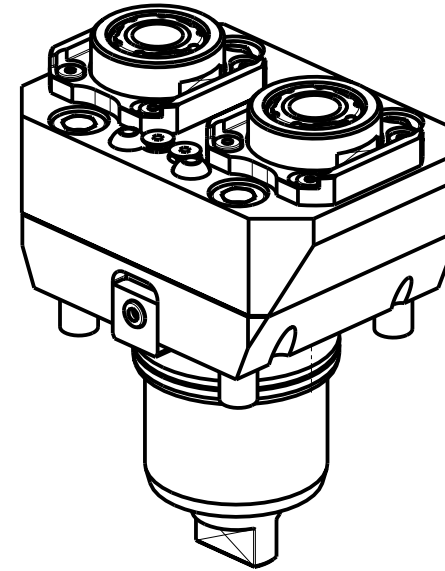
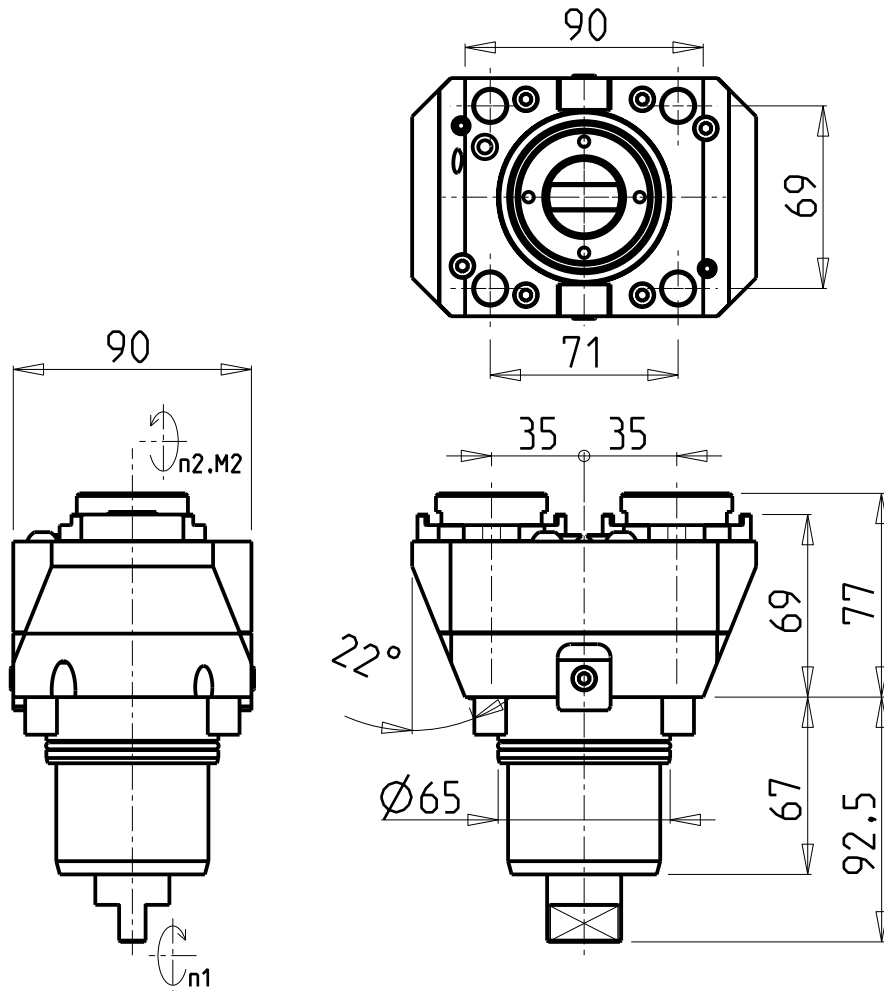

Cod. MT	Mandrino Spindle Spindel	I (n1:n2)	RPM max n2	Coppia Max Max Torque Max Drehmoment M2 (Nm)	Lubrificazione est. Ext. coolant Aussenkuehlung	Lav. secco Dry-run Trocken Bearb.	CHIAVI NON INCLUSE Keys not included Schlüssel nicht inbegriffen		
NKM1120325	ERA25	1:2	12000	30	X	X	CHUB27	CHTAER25ZC	OKU0290009

- Chiave inclusa
- Key included
- Schlüssel inbegriffen

NAKAMURA-TOME

MOD: Super Mill WT150/WT15011/WY250/SC200L - SUPER NTY3 JUMBO

MODULO MOTORIZZATO RADIALE 2 USCITE IN Y MOLTIPLICATO I=1:2

Radial geared-up I=1:2 single side twin head driven tool in Y

Radial angetriebenes Werkzeug 2 Ausgaenge in Y uebersetzt I=1:2

Subject to change without notice.

M.T. srl

Via Casino Albini 480
Tel. 0541/956034-957884
Fax 0541/956341
47842 S. GIOVANNI IN M. (RN)
e-mail: mtma@mtmarchetti.com
http://www.mtmarchetti.com



NKM080-4-10