

ATTENZIONE - ATTENTION - ACHTUNG

- Per lo smontaggio degli utensili utilizzare sempre la chiave di contrasto come indicato nel manuale d'uso.
- For disassembly of the tools use always the contrast key as mentioned in the user instructions.
- Fuer das Abmontieren der Werkzeuge immer den Gegenschlüssel benutzen wie in der Bedienungsanleitung erwäehnt.

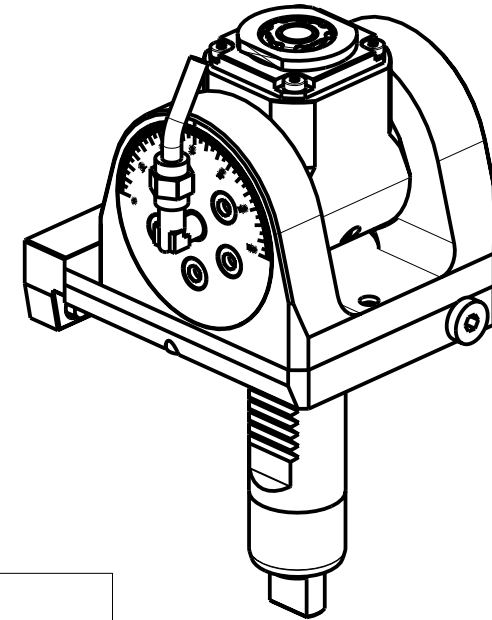

Cod. MT	Mandrino Spindle Spindel	I (n1:n2)	RPM max n2	Coppia Max Max Torque Max Drehmoment	Lubrificazione int. Coolant through Innenkuehlung	Lubrificazione est. Ext. coolant Aussenkuehlung	Lav. secco Dry-run Trocken Bearb.	CHIAVI INCLUSE Keys included Schluessel inbegriffen		
				M2 (Nm)	Pmax (bar)					
MZT0050316	ERA16	1:2	12000	8	-	X	X	CHUB19_SP3	CHUB32	CHTAER16ZC
MZT0050416	ERA16	1:2	12000	8	70	X	-	CHUB19_SP3	CHUB32	CHTAER16ZC

DMG-MORI
MOD: ZT1000/1500 12 STAZIONI

MODULO MOTORIZZATO ORIENTABILE +/-90° MOLTIPLICATO I=1:2
+/-90° adjustable angle driven tool geared-up I=1:2
Angetriebenes Werkzeug schwenkbar +/-90° uebersetzt I=1:2

Subject to change without notice.

M.T. srl

Via Casino Albini 480
Tel. 0541/956034-957884
Fax 0541/956341
47842 S. GIOVANNI IN M. (RN)
e-mail: mtma@mtmarchetti.com
http://www.mtmarchetti.com



MZT336-1-00