

ATTENZIONE - ATTENTION - ACHTUNG

- Per lo smontaggio degli utensili utilizzare sempre la chiave di contrasto come indicato nel manuale d'uso.
- For disassembly of the tools use always the contrast key as mentioned in the user instructions.
- Fuer das Abmontieren der Werkzeuge immer den Gegenschlüssel benutzen wie in der Bedienungsanleitung erwäehnt.

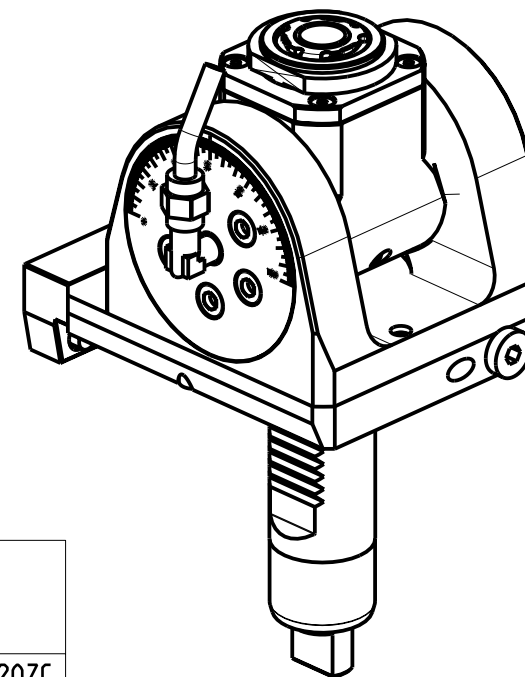

Cod. MT	Mandrino Spindle Spindel	I (n1:n2)	RPM max n2	Coppia Max Max Torque Max Drehmoment	Lubrificazione int. Coolant through Innenkuehlung	Lubrificazione est. Ext. coolant Aussenkuehlung	Lav. secco Dry-run Trocken Bearb.	CHIAVI INCLUSE Keys included Schluesssel inbegriffen		
				M2 (Nm)	Pmax (bar)					
MZT0050120	ER A 20	1:1	6000	30	-	X	X	CHUB36	CHUB22	CHTAER20ZC
MZT0050220	ER A 20	1:1	6000	30	70	X	-	CHUB36	CHUB22	CHTAER20ZC

DMG-MORI
 MOD: ZT1000/1500 12 STAZIONI
 MODULO MOTORIZZATO ORIENTABILE ±90°
 ±90° adjustable angle driven tool
 Angetriebenes Werkzeug schwenkbar ±90°

M.T. srl
 Via Casino Albini 480
 Tel. 0541/956034-957884
 Fax 0541/956341
 47842 S. GIOVANNI IN M. (RN)
 e-mail: mtma@mtmarchetti.com
 http://www.mtmarchetti.com



MZT335-1-00

Subject to change without notice.

09/2025