

ATTENZIONE - ATTENTION - ACHTUNG

- Per lo smontaggio degli utensili utilizzare sempre la chiave di contrasto come indicato nel manuale d'uso.
- For disassembly of the tools use always the contrast key as mentioned in the user instructions.
- Fuer das Abmontieren der Werkzeuge immer den Gegenschlüssel benutzen wie in der Bedienungsanleitung erwäehnt.

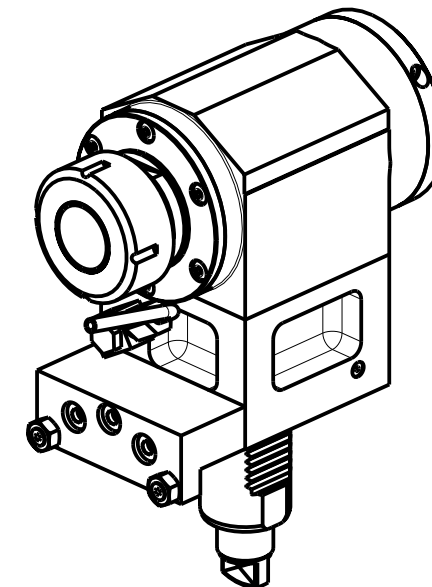

Cod. MT	Mandrino Spindle Spindel	I (n1:n2)	RPM max n2	Coppia Max Max Torque Max Drehmoment M2 (Nm)	Lubrificazione int. Coolant through Innenkuehlung Pmax (bar)	Lubrificazione est. Ext. coolant Aussenkuehlung	Lav. secco Dry-run Trocken Bearb.	B	CHIAVI NON INCLUSE Keys not included Schlüssel nicht einbegriffen	
MMT0011040	ER40	1:1	6000	70	-	X	X	82.95	CHUB46	CHSTER40
MMT0011140	ER40	1:1	6000	70	100 (diag. 2)	X	X	93.95	CHUB46	CHSTER40

DMG-MORI

MOD: MT2000/2500 - ZT2500

MODULO MOTORIZZATO ASSIALE PER CONTROMANDRINO

Axial driven tool sub spindle side

Axial angetriebenes Werkzeug fuer Gegenspindel

Subject to change without notice.

M.T. srl

Via Casino Albini 480
Tel. 0541/956034-957884
Fax 0541/956341
47842 S. GIOVANNI IN M. (RN)
e-mail: mtma@mtmarchetti.com
http://www.mtmarchetti.com



MZT155-2-10

09/2025