

ATTENZIONE - ATTENTION - ACHTUNG

- Per lo smontaggio degli utensili utilizzare sempre la chiave di contrasto come indicato nel manuale d'uso.
- For disassembly of the tools use always the contrast key as mentioned in the user instructions.
- Fuer das Abmontieren der Werkzeuge immer den Gegenschlüssel benutzen wie in der Bedienungsanleitung erwäehnt.

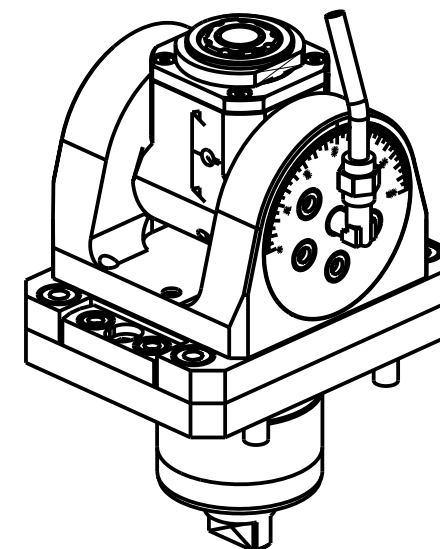

Cod. MT	Mandrino Spindle Spindel	I (n1:n2)	RPM max n2	Coppia Max Max Torque Max Drehmoment M2 (Nm)	Reversibile 180° 180° Reversible 180° umsetzbar	Lubrificazione int. Coolant through Innenkuehlung Pmax (bar)	Lubr.esterna Ext. coolant Aussenkuehlung	Lav. secco Dry-run Trocken Bearb.	CHIAVI INCLUSE Keys included Schlüssel inbegriffen			
MYA0120120	ERA20	1:1	6000	30	X	-	X	X	CHUB36	CHUB22	CHESL06	CHTAER20ZC
MYA0120220	ERA20	1:1	6000	30	X	70	X	-	CHUB36	CHUB22	CHESL06	CHTAER20ZC

MIYANO

MOD: ABX-51/64/80 SYY/THY

MODULO MOTORIZZATO ORIENTABILE +/-90° H=60mm
 +/-90° adjustable angle driven tool H=60mm
 Angetriebenes Werkzeug schwenkbar +/-90° H=60mm

Subject to change without notice.

M.T. srl

Via Casino Albini 480
 Tel. 0541/956034-957884
 Fax 0541/956341
 47842 S. GIOVANNI IN M. (RN)
 e-mail: mtma@mtmarchetti.com
 http://www.mtmarchetti.com



MYA335-3-00

09/2025