

ATTENZIONE - ATTENTION - ACHTUNG

- Per lo smontaggio degli utensili utilizzare sempre la chiave di contrasto come indicato nel manuale d'uso.
- For disassembly of the tools use always the contrast key as mentioned in the user instructions.
- Fuer das Abmontieren der Werkzeuge immer den Gegenschlüssel benutzen wie in der Bedienungsanleitung erwaeht.

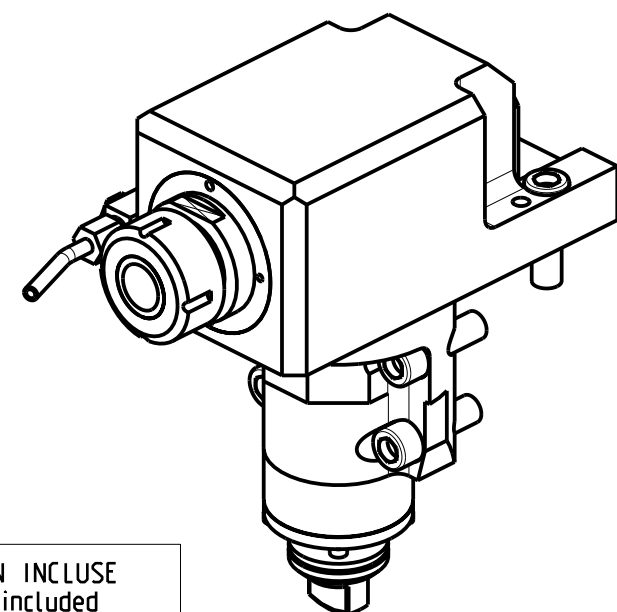

Cod. MT	Mandrino Spindle Spindel	I (n1:n2)	RPM max n2	Coppia Max Max Torque Max Drehmoment M2 (Nm)	Lubrificazione int. Coolant through Innenkuehlung Pmax (bar)	Lubrificazione est. Ext. coolant Aussenkuehlung	Lav. secco Dry-run Trocken Bearb.	A	A1	CHIAVI NON INCLUSE Keys not included Schlüssel nicht einbegriffen	
M0290132	ER32	1:1	6000	70	70	X	-	112.16	-	CHUB46	CHSTER32
M0290232	ER32	1:1	6000	70	-	X	X	112.16	-	CHUB46	CHSTER32
M0290140	ER40	1:1	6000	70	70	X	-	115.16	-	CHUB46	CHSTER40
M0290332	WELDON 32	1:1	6000	70	70	X	-	-	131.5	-	-

DMG-MORI
 MOD: SL300/303
 MODULO MOTORIZZATO ASSIALE
 Axial driven tool
 Axial angetriebenes Werkzeug

M.T. srl
 Via Casino Albini 480
 Tel. 0541/956034-957884
 Fax 0541/956341
 47842 S. GIOVANNI IN M. (RN)
 e-mail: mtma@mtmarchetti.com
 http://www.mtmarchetti.com



MSL150-3-10

Subject to change without notice.