

### ATTENZIONE - ATTENTION - ACHTUNG

- Per lo smontaggio degli utensili utilizzare sempre la chiave di contrasto come indicato nel manuale d'uso.
- For disassembly of the tools use always the contrast key as mentioned in the user instructions.
- Fuer das Abmontieren der Werkzeuge immer den Gegenschlüssel benutzen wie in der Bedienungsanleitung erwaeht.

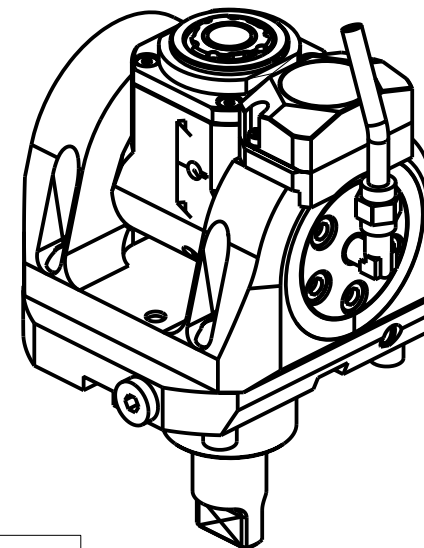

| Cod. MT    | Mandrino Spindle Spindel | I (n1:n2) | RPM max n2 | Coppia Max Max Torque Max Drehmoment<br>M2 (Nm) | Lubrificazione int. Coolant through Innenkuehlung<br>Pmax (bar) | Lubrificazione est. Ext. coolant Aussenkuehlung | Lav. secco Dry-run Trocken Bearb. | CHIAVI INCLUDE<br>Keys included<br>Schluessel inbegriffen |        |         |            |
|------------|--------------------------|-----------|------------|---|---|---|-----------------------------------|---|--------|---------|------------|
| MNZ0585120 | ER A 20                  | 1:1       | 12000      | 30  | -   | X   | X                                 | CHUB36  | CHUB22 | CHESL08 | CHTAER20ZC |
| MNZ0585220 | ER A 20                  | 1:1       | 12000      | 30  | 70  | X   | -                                 | CHUB36  | CHUB22 | CHESL08 | CHTAER20ZC |

### DMG-MORI

NZ1500/2000 - NZX1500/2000 - NZX2500 (BMT40) - NTX1000/2000 - NTX1000/2000/2500/3000 2ND GEN. 12ST. - NRX2000  
ALC/ALX1500/2000/2500 (BMT40)

MODULO MOTORIZZATO ORIENTABILE +/-90° 12000 RPM CON NONIO DIGITALE H=50mm  
+/-90° adjustable angle driven tool 12000 rpm with digital display H=50mm  
Angetriebenes Werkzeug schwenkbar +/-90° 12000 rpm mit digital display H=50mm

### M.T. srl

Via Casino Albini 480  
Tel. 0541/956034-957884  
Fax 0541/956341  
47842 S. GIOVANNI IN M. (RN)  
e-mail: mtma@mtmarchetti.com  
http://www.mtmarchetti.com



MNZ335-1-03

Subject to change without notice.

09/2025