

### ATTENZIONE - ATTENTION - ACHTUNG

- Per lo smontaggio degli utensili utilizzare sempre la chiave di contrasto come indicato nel manuale d'uso.
- For disassembly of the tools use always the contrast key as mentioned in the user instructions.
- Fuer das Abmontieren der Werkzeuge immer den Gegenschlüssel benutzen wie in der Bedienungsanleitung erwäehnt.

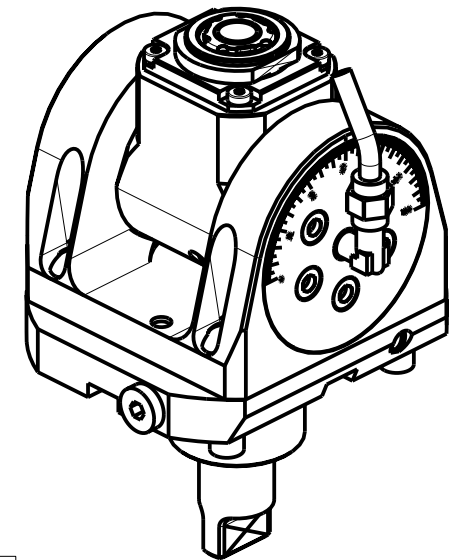

Cod. MT	Mandrino Spindle Spindel	I (n1:n2)	RPM max n2	Coppia Max Max Torque Max Drehmoment	Lubrificazione int. Coolant through Innenkuehlung	Lubrificazione est. Ext. coolant Aussenkuehlung	Lav. secco Dry-run Trocken Bearb.	CHIAVI INCLUDE Keys included Schluessel inbegriffen			
				M2 (Nm)	Pmax (bar)						
MNZ0580120	ER A 20	1:1	12000	30	-	X	X	CHUB36	CHUB22	CHESL08	CHTAER20ZC
MNZ0580220	ER A 20	1:1	12000	30	70	X	-	CHUB36	CHUB22	CHESL08	CHTAER20ZC

### DMG-MORI

NZ1500/2000 - NZX1500/2000 - NZX2500 (BMT40) - NTX1000/2000 - NTX1000/2000/2500/3000 2ND GEN. 12ST. - NRX2000 ALC/ALX1500/2000/2500 (BMT40)

MODULO MOTORIZZATO ORIENTABILE +/-90° 12000 RPM H=50mm  
 +/-90° adjustable angle driven tool 12000 rpm H=50mm  
 Angetriebenes Werkzeug schwenkbar +/-90° 12000 rpm H=50mm

Subject to change without notice.

### M.T. srl

Via Casino Albini 480  
 Tel. 0541/956034-957884  
 Fax 0541/956341  
 47842 S. GIOVANNI IN M. (RN)  
 e-mail: mtma@tmarchetti.com  
 http://www.tmmarchetti.com



MNZ335-1-02