

### ATTENZIONE - ATTENTION - ACHTUNG

- Per lo smontaggio degli utensili utilizzare sempre la chiave di contrasto come indicato nel manuale d'uso.
- For disassembly of the tools use always the contrast key as mentioned in the user instructions.
- Fuer das Abmontieren der Werkzeuge immer den Gegenschlüssel benutzen wie in der Bedienungsanleitung erwäehnt.

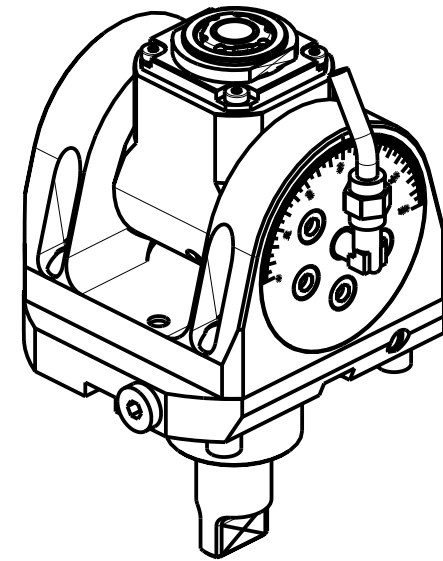

Cod. MT	Mandrino Spindle Spindel	I (n1:n2)	RPM max n2	Coppia Max Max Torque Max Drehmoment	Lubrificazione int. Coolant through Innenkuehlung	Lubrificazione est. Ext. coolant Aussenkuehlung	Lav. secco Dry-run Trocken Bearb.	CHIAVI INCLUDE Keys included Schluessel inbegriffen			
				M2 (Nm)	Pmax (bar)						
MNZ0390120	ER A 20	1:1	6000	30	-	X	X	CHUB36	CHUB22	CHESL08	CHTAER20ZC
MNZ0390220	ER A 20	1:1	6000	30	70	X	-	CHUB36	CHUB22	CHESL08	CHTAER20ZC

DMG-MORI

NZ1500/2000 - NZX1500/2000 - NZX2500 (BMT40) - NT3100/3150/3200 - NT1000/2000 - NTX1000/2000 - NTX1000/2000/2500/3000 2ND GEN. 12ST.  
 DURATURN 2050MC/2550MC - NRX2000 - ALC/ALX1500/2000/2500 (BMT40) - ECOTURN 450 (BMT40)

MODULO MOTORIZZATO ORIENTABILE +/-90° H=50mm  
 +/-90° adjustable angle driven tool H=50mm  
 Angetriebenes Werkzeug schwenkbar +/-90° H=50mm

Subject to change without notice.

**M.T. srl**

Via Casino Albini 480  
 Tel. 0541/956034-957884  
 Fax 0541/956341  
 47842 S. GIOVANNI IN M. (RN)  
 e-mail: mtma@mtmarchetti.com  
 http://www.mtmarchetti.com



MNZ335-1-00