

ATTENZIONE - ATTENTION - ACHTUNG

- VERIFICARE LE MISURE DI INGOMBRO PER POSSIBILE INTERFERENZA SU ALCUNI MODELLI DI MACCHINE
- Please check the overall sizes for possible interferences on some machine models
- Bitte überprüfen sie das ausmass um mögliche interferenzen auf einigen maschinen modellen zu vermeiden

ATTENZIONE - ATTENTION - ACHTUNG

- Per lo smontaggio degli utensili utilizzare sempre la chiave di contrasto come indicato nel manuale d'uso.
- For disassembly of the tools use always the contrast key as mentioned in the user instructions.
- Fuer das Abmontieren der Werkzeuge immer den Gegenschlüssel benutzen wie in der Bedienungsanleitung erwäehnt.

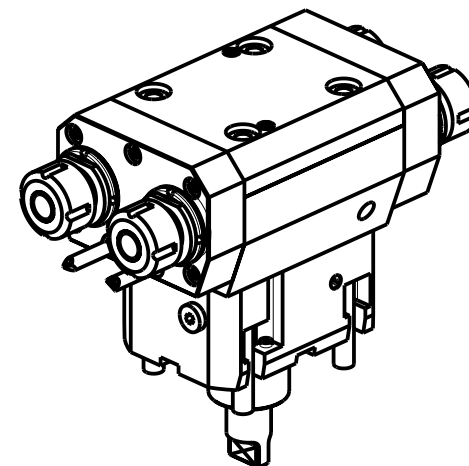
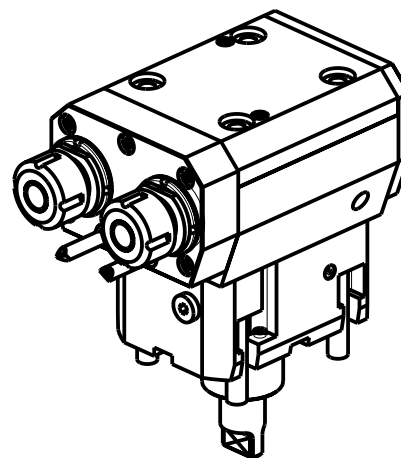

| Cod. MT | Mandrino Spindle Spindel | I (n1:n2) | RPM max n2 | Coppia Max Max Torque Max Drehmoment M2 (Nm) | N°Utensili N° Tools N° Werkzeuge | Reversibile 180° 180° Reversible 180° umsetzbar | Lubr.esterna Ext. coolant Aussenkuehlung | Lav. secco Dry-run Trocken Bearb. | A | B | CHIAVI NON INCLUSE Keys not included Schluessel nicht einbegriffen | |
|------------|--------------------------|-----------|------------|--|----------------------------------|---|--|-----------------------------------|--------|--------|--|------------|
| | | | | | | | | | | | | |
| MNZ0041316 | ERA16 | 1:1 | 6000 | 40 | 2 | X | X | X | 96.63 | - | CHUB32 | CHUB19_SP3 |
| MNZ0041320 | ER20 | 1:1 | 6000 | 40 | 2 | X | X | X | 113.16 | - | CHUB32 | CHSTER20 |
| MNZ0041416 | ERA16+ERA16 | 1:1 | 6000 | 40 | 2+2 | X | X | X | 96.63 | 96.63 | CHUB32 | CHUB19_SP3 |
| MNZ0041420 | ER20+ER20 | 1:1 | 6000 | 40 | 2+2 | X | X | X | 113.16 | 113.16 | CHUB32 | CHSTER20 |

DMG-MORI

NZ1500/2000 - NZX1500/2000 - NT3100/3150/3200 - NL1500/2000/2500 20 ST. - NLX1500/2000/2500 20 ST. - NLX2500 2ND GEN. 20ST.
 NT1000/2000 - DURATURN 2050MC/2550MC - ALC/ALX1500/2000/2500 (BMT40)

MODULO MOTORIZZATO ASSIALE 2/4 USCITE IN Y H=100mm

Axial multiple 2/4 outlet driven tool in Y H=100mm

Axial angetriebenes Mehrspindel-Werkzeug 2/4 Ausgaenge in Y H=100mm

M.T. srl

Via Casino Albini 480
 Tel. 0541/956034-957884
 Fax 0541/956341
 47842 S. GIOVANNI IN M. (RN)
 e-mail: mtma@mtmarchetti.com
 http://www.mtmarchetti.com



MNZ268-1-10

Subject to change without notice.

09/2025