

ATTENZIONE - ATTENTION - ACHTUNG

- VERIFICARE LE MISURE DI INGOMBRO PER POSSIBILE INTERFERENZA SU ALCUNI MODELLI DI MACCHINE
- Please check the overall sizes for possible interferences on some machine models
- Bitte überprüfen sie das ausmass um mögliche interferenzen auf einigen maschinen modellen zu vermeiden

ATTENZIONE - ATTENTION - ACHTUNG

- Per lo smontaggio degli utensili utilizzare sempre la chiave di contrasto come indicato nel manuale d'uso.
- For disassembly of the tools use always the contrast key as mentioned in the user instructions.
- Fuer das Abmontieren der Werkzeuge immer den Gegenschlüssel benutzen wie in der Bedienungsanleitung erwaeht.

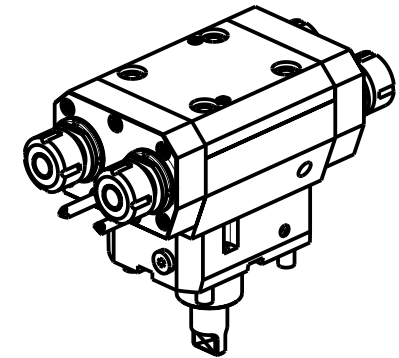
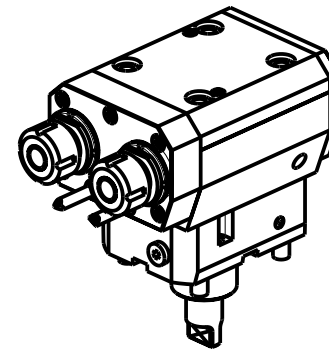
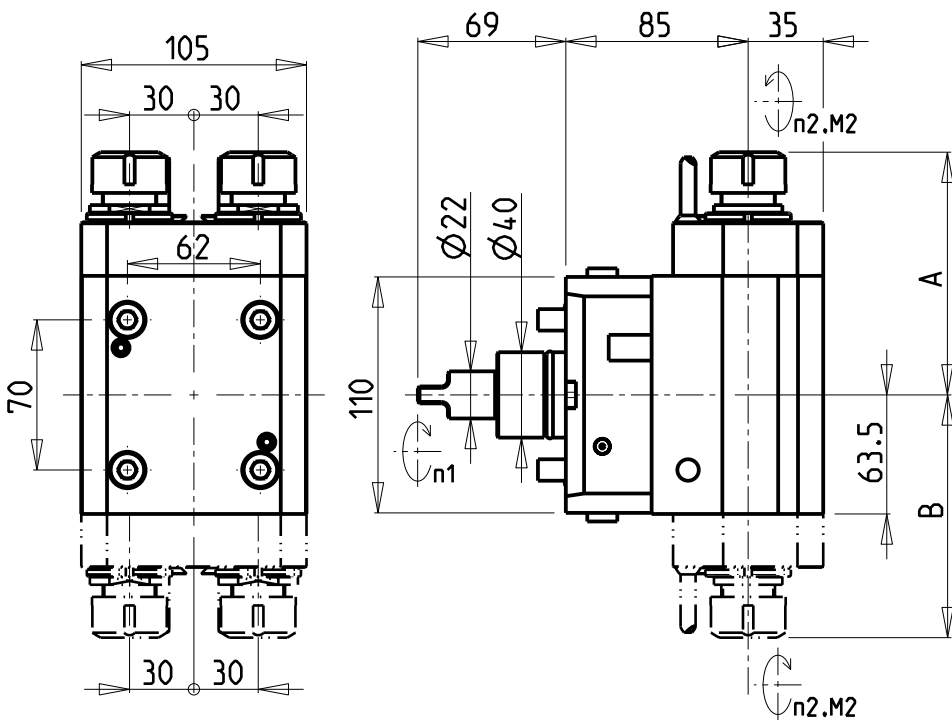

Cod. MT	Mandrino Spindle Spindel	I (n1:n2)	RPM max n2	Coppia Max Max Torque Max Drehmoment M2 (Nm)	N°Utensili N°Tools N°Werkzeuge	Reversibile 180° 180° Reversible 180° umsetzbar	Lubr.esterna Ext. coolant Aussenkuehlung	Lav. secco Dry-run Trocken Bearb.	A	B	CHIAVI NON INCLUDE Keys not included Schluessel nicht einbegriffen	
MNZ0040316	ERA16	1:1	6000	40	2	X	X	X	96.63	-	CHUB32	CHUB19_SP3
MNZ0040320	ER20	1:1	6000	40	2	X	X	X	113.16	-	CHUB32	CHSTER20
MNZ0040416	ERA16+ERA16	1:1	6000	40	2+2	X	X	X	96.63	96.63	CHUB32	CHUB19_SP3
MNZ0040420	ER20+ER20	1:1	6000	40	2+2	X	X	X	113.16	113.16	CHUB32	CHSTER20

DMG-MORI

NZ1500/2000 - NZX1500/2000 - NT3100/3150/3200 - NL1500/2000/2500 20 ST. - NLX1500/2000/2500 20 ST. - NLX2500 2ND GEN. 20ST. - NT1000/2000 NTX500 (BMT40) - DURATURN 2050MC/2550MC - ALC/ALX1500/2000/2500 (BMT40) - ECOTURN 450 (BMT40) - NZ DUE/TRE/QUATTRO (BMT40)

MODULO MOTORIZZATO ASSIALE 2/4 USCITE IN Y H=85mm

Axial multiple 2/4 outlet driven tool in Y H=85mm

Axial angetriebenes Mehrspindel-Werkzeug 2/4 Ausgaenge in Y H=85mm

M.T. srl

Via Casino Albini 480
Tel. 0541/956034-957884
Fax 0541/956341
47842 S. GIOVANNI IN M. (RN)
e-mail: mtma@mtmarchetti.com
http://www.mtmarchetti.com



MNZ268-1-00

Subject to change without notice.

09/2025