

ATTENZIONE - ATTENTION - ACHTUNG

- VERIFICARE LE MISURE DI INGOMBRO PER POSSIBILE INTERFERENZA SU ALCUNI MODELLI DI MACCHINE
- Please check the overall sizes for possible interferences on some machine models
- Bitte überprüfen sie das ausmass um mögliche interferenzen auf einigen maschinen modellen zu vermeiden

ATTENZIONE - ATTENTION - ACHTUNG

- Per lo smontaggio degli utensili utilizzare sempre la chiave di contrasto come indicato nel manuale d'uso.
- For disassembly of the tools use always the contrast key as mentioned in the user instructions.
- Fuer das Abmontieren der Werkzeuge immer den Gegenschlüssel benutzen wie in der Bedienungsanleitung erwahnt.

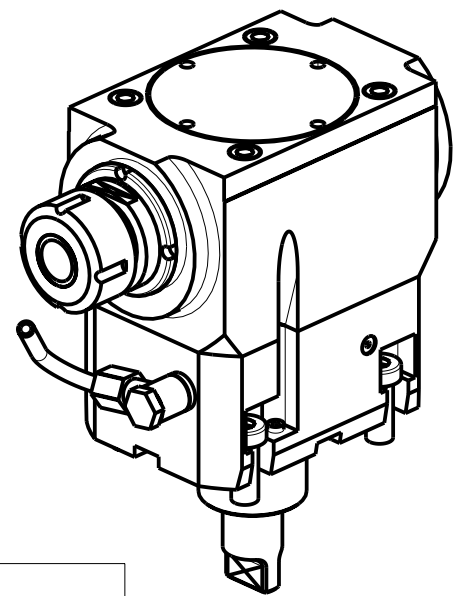

| Cod. MT | Mandrino Spindle Spindel | I (n1:n2) | RPM max n2 | Coppia Max Max Torque Max Drehmoment M2 (Nm) | Reversibile 180° 180° Reversible 180° umsetzbar | Lubrificazione int. Coolant through Innenkuehlung Pmax (bar) | Lubrificazione est. Ext. coolant Aussenkuehlung | Lav. secco Dry-run Trocken Bearb. | B | CHIAVI NON INCLUSE Keys not included Schluessel nicht einbegriffen | |
|------------|--------------------------|-----------|------------|--|---|--|---|-----------------------------------|----|--|----------|
| MNZ0081125 | ER25 | 1:2 | 12000 | 30 | X | - | X | X | 67 | CHUB36 | CHSTER25 |
| MNZ0081225 | ER25 | 1:2 | 12000 | 30 | X | 100 (diag. 2) | X | X | 77 | CHUB36 | CHSTER25 |

DMG-MORI
 NZ1500/2000 - NZX1500/2000 - NT3100/3150/3200 - NL1500/2000/2500 20 ST. - NLX1500/2000/2500 20 ST. - NLX2500 2ND GEN. 20ST. - NT1000/2000 - NTX500 (BMT40)
 NTX1000/2000 - NTX1000/2000/2500/3000 2ND GEN. 12ST. - DURATURN 2050MC/2550MC - ALC/ALX1500/2000/2500 (BMT40) - NZ DUE/TRE/QUATTRO (BMT40)

MODULO MOTORIZZATO ASSIALE MOLTIPLICATO I=1:2 H=100mm
 Axial geared-up I=1:2 driven tool H=100mm
 Axial angetriebenes Werkzeug uebersetzt I=1:2 H=100mm

M.T. srl
 Via Casino Albini 480
 Tel. 0541/956034-957884
 Fax 0541/956341
 47842 S. GIOVANNI IN M. (RN)
 e-mail: mtma@mtmarchetti.com
 http://www.mtmarchetti.com



MNZ200-1-20

Subject to change without notice.