

### ATTENZIONE - ATTENTION - ACHTUNG

- Per lo smontaggio degli utensili utilizzare sempre la chiave di contrasto come indicato nel manuale d'uso.
- For disassembly of the tools use always the contrast key as mentioned in the user instructions.
- Fuer das Abmontieren der Werkzeuge immer den Gegenschlüssel benutzen wie in der Bedienungsanleitung erwaeht.

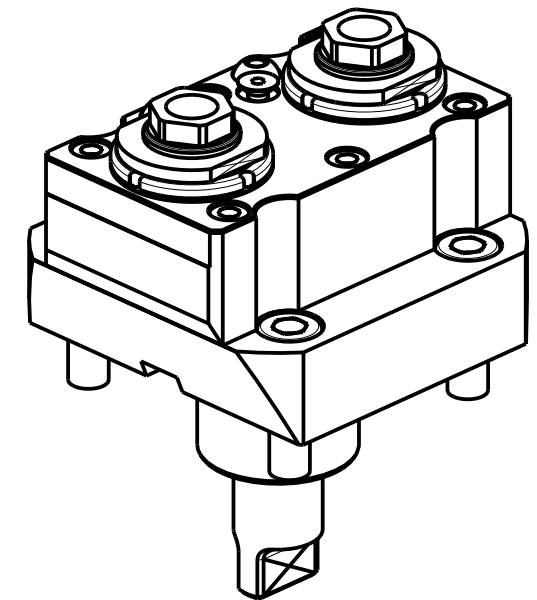

Cod. MT	Mandrino Spindle Spindel	I (n1:n2)	RPM max n2	Coppia Max Max Torque Max Drehmoment M2 (Nm)	Lubrificazione int. Coolant through Innenkuehlung Pmax (bar)	Lubrificazione est. Ext. coolant Aussenkuehlung	Lav. secco Dry-run Trocken Bearb.	A	CHIAVI NON INCLUSE Keys not included Schlüssel nicht einbegriffen	
MNZ0030416	ERA16	1:1	6000	30	-	X	X	73.13	CHUB32	CHUB19_SP3
MNZ0030516	ERA16	1:1	6000	30	70	X	-	83.13	CHUB32	CHUB19_SP3
MNZ0030420	ER20	1:1	6000	30	-	X	X	89.66	CHUB32	CHSTER20
MNZ0680220	ER20	1:1	6000	30	100 (diag. 2)	X	X	96.16	CHUB32	CHSTER20

DMG-MORI

NZ1500/2000 - NZX1500/2000 - NT3100/3150/3200 - NL1500/2000/2500 20 ST. - NLX1500/2000/2500 20 ST. - NLX2500 2ND GEN. 20ST. - NT1000/2000 - NTX500 (BMT40)  
NTX1000/2000/2500/3000 2ND GEN. 12ST. - DURATURN 2050MC/2550MC - ALC/ALX1500/2000/2500 (BMT40) - ECOTURN 450 (BMT40) - NZ DUE/TRE/QUATTRO (BMT40)

MODULO MOTORIZZATO RADIALE 2 USCITE IN Y

Radial single side twin head driven tool in Y

Radial angetriebenes Werkzeug 2 Ausgaenge ueberlagert in Y

Subject to change without notice.

M.T. srl

Via Casino Albini 480  
Tel. 0541/956034-957884  
Fax 0541/956341  
47842 S. GIOVANNI IN M. (RN)  
e-mail: mtma@mtmarchetti.com  
http://www.mtmarchetti.com



MNZ080-1-00

09/2025