

ATTENZIONE - ATTENTION - ACHTUNG

- Per lo smontaggio degli utensili utilizzare sempre la chiave di contrasto come indicato nel manuale d'uso.
- For disassembly of the tools use always the contrast key as mentioned in the user instructions.
- Fuer das Abmontieren der Werkzeuge immer den Gegenschlüssel benutzen wie in der Bedienungsanleitung erwäehnt.

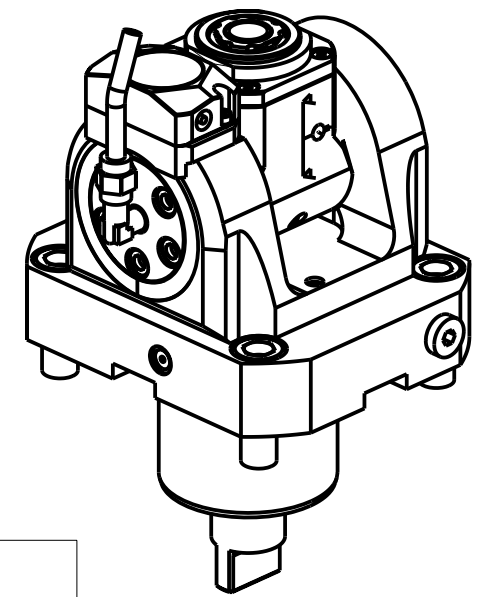

| Cod. MT | Mandrino Spindle Spindel | I (n1:n2) | RPM max n2 | Coppia Max Max Torque Max Drehmoment | Lubrificazione int. Coolant through Innenkuehlung | Lubrificazione est. Ext. coolant Aussenkuehlung | Lav. secco Dry-run Trocken Bearb. | CHIAVI INCLUSE Keys included Schluessel inbegriffen | | | |
|------------|--------------------------|-----------|------------|--------------------------------------|---|---|-----------------------------------|---|--------|------------|---------|
| | | | | M2 (Nm) | Pmax (bar) | | | | | | |
| MNL0645120 | ERA20 | 1:1 | 6000 | 30 | - | X | X | CHUB22 | CHUB36 | CHTAER20ZC | CHESL10 |
| MNL0645220 | ERA20 | 1:1 | 6000 | 30 | 70 | X | - | CHUB22 | CHUB36 | CHTAER20ZC | CHESL10 |

DMG-MORI
 NL1500/2000/2500/3000 12 ST. - NLX1500/2000/2500/3000 12 ST. - NLX2500 2ND GEN. 10/12ST. - NLX4000 - NZL2000/2500
 NZX2500 (BMT60) - NT4200/4250/4300/5400 - NTX2000/2500/3000 2ND GEN. 10ST. - CTX2500 (BMT60)
MODULO MOTORIZZATO ORIENTABILE +/-90° CON NONIO DIGITALE
 +/-90° adjustable angle driven tool with digital display
 Angetriebenes Werkzeug schwenkbar +/-90° mit digital display

M.T. srl
 Via Casino Albini 480
 Tel. 0541/956034-957884
 Fax 0541/956341
 47842 S. GIOVANNI IN M. (RN)
 e-mail: mtma@mtmarchetti.com
 http://www.mtmarchetti.com

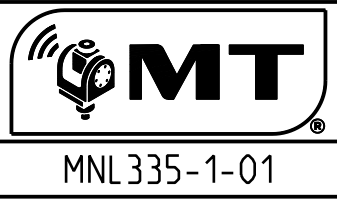

Subject to change without notice.