

ATTENZIONE - ATTENTION - ACHTUNG

- Per lo smontaggio degli utensili utilizzare sempre la chiave di contrasto come indicato nel manuale d'uso.
- For disassembly of the tools use always the contrast key as mentioned in the user instructions.
- Fuer das Abmontieren der Werkzeuge immer den Gegenschlüssel benutzen wie in der Bedienungsanleitung erwaeht.

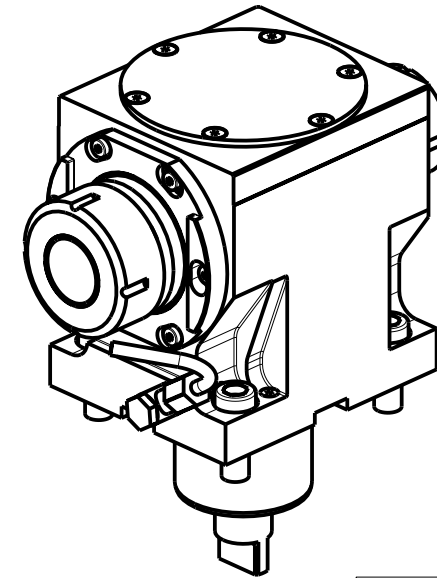
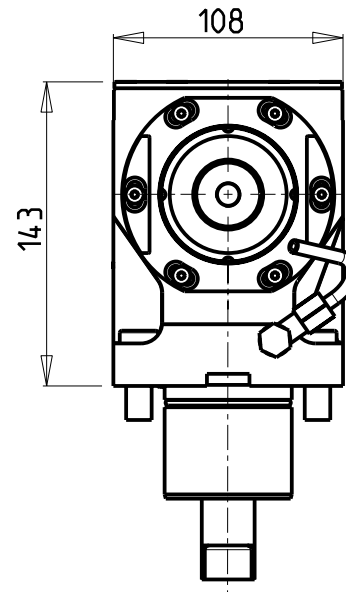
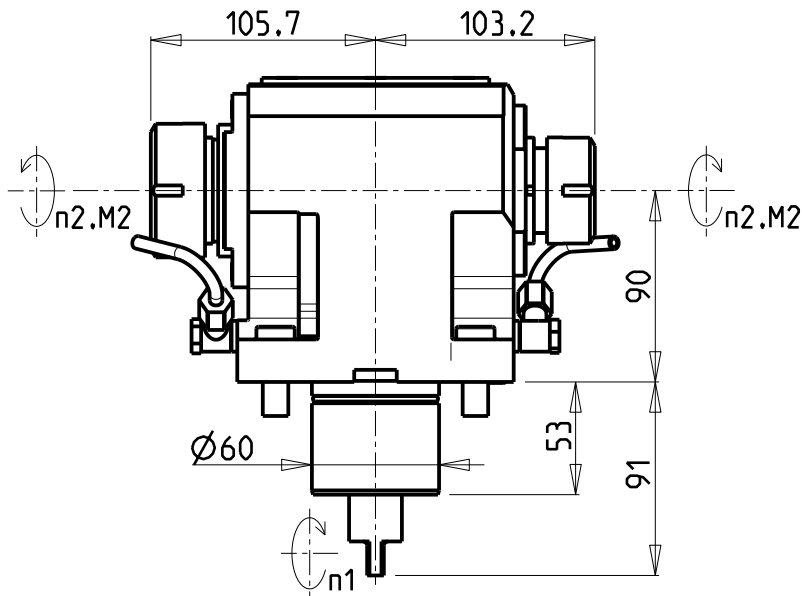
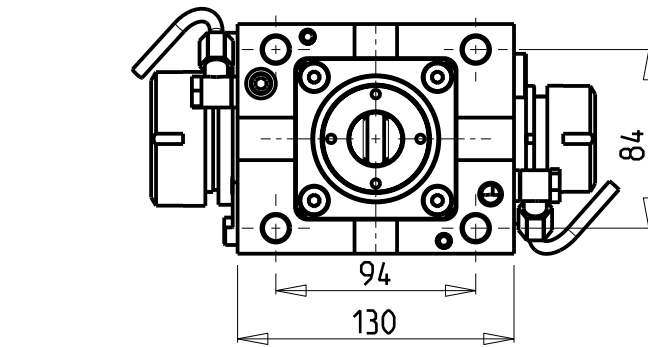

- Chiave inclusa
- Key included
- Schluessel inbegriffen

CHIAVI NON INCLUSE
Keys not included
Schluessel nicht einbegriffen

Cod. MT	Mandrino Spindle Spindel	I (n1:n2)	RPM max n2	Coppia Max Max Drehmoment M2 (Nm)	Reversibile 180° 180° Reversible 180° umsetzbar	Lubr.esterna Ext. coolant Aussenkuehlung	Lav. secco Dry-run Trocken Bearb.	OKU0430007 *	CHSTER40	CHSTER32
MNL0914032	ER40+ER32	2:1	3000	130	X	X	X			

DMG-MORI

NL1500/2000/2500/3000 12 ST. - NLX1500/2000/2500/3000 12 ST. - NLX2500 2ND GEN. 10/12ST. - NLX4000 - NZL2000/2500 NZX2500 (BMT60) - NT4200/4250/4300/5400 - CTX2500 (BMT60)

MODULO MOTORIZZATO ASSIALE BISPORGENTE RIDOTTO I=2:1 H=90mm

Axial geared-down I=2:1 opposite face twin driven tool H=90mm

Axial angetriebenes Werkzeug halb vorspringend untersetzt I=2:1 H=90mm

Subject to change without notice.

M.T. srl

Via Casino Albini 480
Tel. 0541/956034-957884
Fax 0541/956341
47842 S. GIOVANNI IN M. (RN)
e-mail: mtma@mtmarchetti.com
http://www.mtmarchetti.com



MNL247-1-10