

ATTENZIONE - ATTENTION - ACHTUNG

- VERIFICARE LE MISURE DI INGOMBRO PER POSSIBILE INTERFERENZA SU ALCUNI MODELLI DI MACCHINE
- Please check the overall sizes for possible interferences on some machine models
- Bitte überprüfen sie das ausmass um mögliche interferenzen auf einigen maschinen modellen zu vermeiden

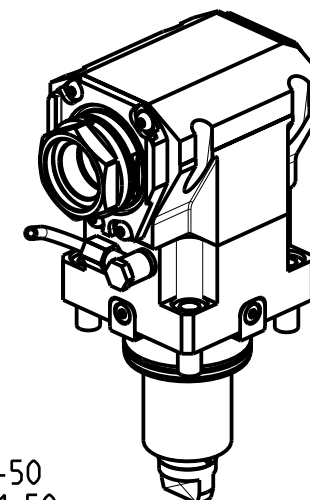

PER PORTAUTENSILI MODULARI MTSK-40 VEDI PAG. TBL300-1-40 E PER MTSK-50 VEDI PAG. TBL300-1-50
 FOR MTSK-40 QUICK CHANGE TOOLHOLDERS CLAMPINGS SEE PAGE TBL300-1-40 AND FOR MTSK-50 SEE PAGE TBL300-1-50
 FUER MTSK-40 MODULARE WERKZEUGAUFNAHMEN SIEHE SEITE TBL300-1-40 UND FUER MTSK-50 SIEHE SEITE TBL300-1-50

| Cod. MT | Mandrino Spindle Spindel | I (n1:n2) | RPM max n2 | Coppia Max Max Drehmoment | Reversibile 180° 180° Reversible 180° umsetzbar | Lubrificazione int. Coolant through Innenkuehlung | Lubr.esterna Ext. coolant Aussenkuehlung | Lav. secco Dry-run Trocken Bearb. | A | B | CHIAVI NON INCLUDE Keys not included Schlüssel nicht einbegriffen | |
|-------------|--------------------------------|--------------|------------------|------------------------------|---|---|--|---|----|----|---|--------------|
| | | | | M2 (Nm) | | Pmax (bar) | | | | | | |
| DW 01190140 | MTSK-40 | 1:1 | 6000 | 100 | X | - | X | X | 77 | 54 | CHUB46 | OKU0650004 • |
| DW 01190240 | MTSK-40 | 1:1 | 6000 | 100 | X | 100 (diag. 2) | X | X | 77 | 65 | CHUB46 | OKU0650004 • |
| DW 01190150 | MTSK-50 | 1:1 | 6000 | 100 | X | - | X | X | 79 | 54 | CHUB55 | OKU0650004 • |
| DW 01190250 | MTSK-50 | 1:1 | 6000 | 100 | X | 100 (diag. 2) | X | X | 79 | 65 | CHUB55 | OKU0650004 • |

- Chiave inclusa
- Key included
- Schlüssel inbegriffen

HYUNDAI-WIA (KIA)

SKT200TTM/TTMS/TTSY - LM2000TTM/TTMS/TTSY - L2000/2600/3000Y/SY - L300M/LM/MS/LMS
 SKT250TTM/TTMS/TTSY - LM2500TTM/TTMS/TTSY - SKT250M/LM/MS - SKT300M/LM/MS - SKT-V3RM/LM - LV450RM/LM - HD2600/3100 (BMT65)

MODULO MOTORIZZATO ASSIALE MTSK H=100mm

Axial MTSK driven tool H=100mm

Axial MTSK angetriebenes Werkzeug H=100mm

Subject to change without notice.

M.T. srl

Via Casino Albini 480
 Tel. 0541/956034-957884
 Fax 0541/956341
 47842 S. GIOVANNI IN M. (RN)
 e-mail: mtma@tmarchetti.com
 http://www.tmmarchetti.com



KIA150-3-21-K