

INCLINAZIONE
REGOLABILE $\pm 30^\circ$

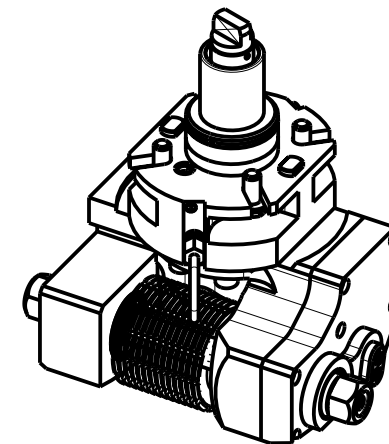
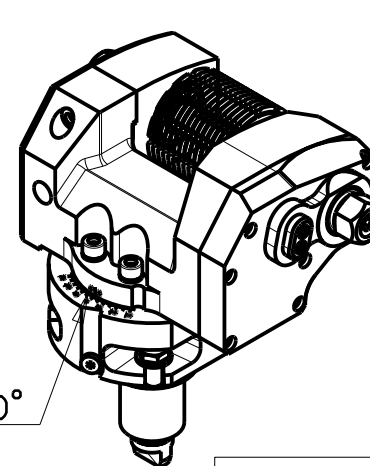

ATTENZIONE - ATTENTION - ACHTUNG

- VERIFICARE LE MISURE DI INGOMBRO PER POSSIBILE INTERFERENZA SU ALCUNI MODELLI DI MACCHINE
- Please check the overall sizes for possible interferences on some machine models
- Bitte überprüfen sie das ausmass um mögliche interferenzen auf einigen maschinen modellen zu vermeiden

-LA FUNZIONE DI POLIGONATURA/DENTATURA DEVE ESSERE INSTALLATA SULLA MACCHINA
-POLYGON CUTTING/GEAR HOBBING FUNCTION MUST BE INSTALLED ON THE MACHINE
-DIE FUNKTION FÜR POLYGON-BZW .VERZÄHNUNGSFRÄSEN MUSS AUF DER MASCHINE FREIGESCHALTET WERDEN

DOTAZIONI - SUPPLIED WITH - AUSSTATTUNG

mm / inch

- N°1 ALBERO + DISTANZIALI
- N°1 SHAFT + SPACER
- N°1 DORN + ABSTANDSSTUECK

PER ALBERI E DISTANZIALI VEDI PAG. TBL250-1-00
FOR SHAFT END SPACER SEE PAGE TBL250-1-00
FUER DORN UND ABSTANDSSTUECK SEITE TBL250-1-00

Cod. MT	I (n1:n2)	RPM max n2	Coppia Max Max Torque Max Drehmoment M2 (Nm)	Lubr.esterna Ext. coolant Aussenkuehlung	Lav. secco Dry-run Trocken Bearb.	D (mm)	D (Inch)	CHIAVI INCLUSE Keys included Schlüssel inbegriffen			
								CHUB30	CHUB19	CHESLO8	CHUB24 (Ø16 / Ø3/4")
DW00031100	1:1	6000	90	X	X	16-22-27-32	3/4"-1"-1 1/4"	CHUB30	CHUB19	CHESLO8	CHUB24 (Ø16 / Ø3/4")
DW00032100	2:1	3000	110	X	X	16-22-27-32	3/4"-1"-1 1/4"	CHUB30	CHUB19	CHESLO8	CHUB24 (Ø16 / Ø3/4")

HURCO

MOD: TMX8-TMX10 MY/MYS (BMT65)

MODULO MOTORIZZATO PORTACREATORE MAGGIORATO

Reinforced driven gear hobber

Angetriebenes Zahnradwaelzfraes-Werkzeug vergroessert

Subject to change without notice.

M.T. srl

Via Casino Albini 480
Tel. 0541/956034-957884
Fax 0541/956341
47842 S. GIOVANNI IN M. (RN)
e-mail: mtma@mtmarchetti.com
http://www.mtmarchetti.com



HUR340-1-60

09/2025