

**ATTENZIONE - ATTENTION - ACHTUNG**

- VERIFICARE LE MISURE DI INGOMBRO PER POSSIBILE INTERFERENZA SU ALCUNI MODELLI DI MACCHINE
- Please check the overall sizes for possible interferences on some machine models
- Bitte überprüfen sie das ausmass um mögliche interferenzen auf einigen maschinen modellen zu vermeiden

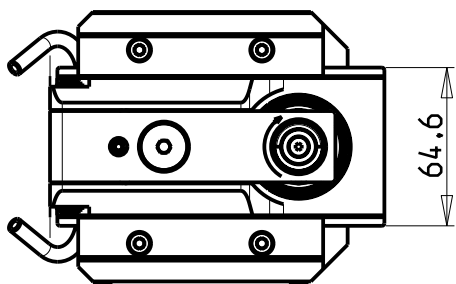
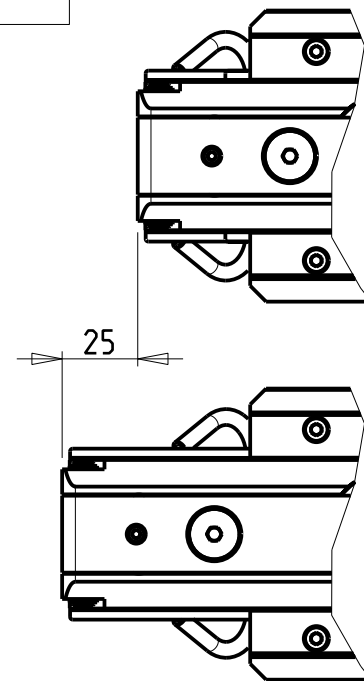
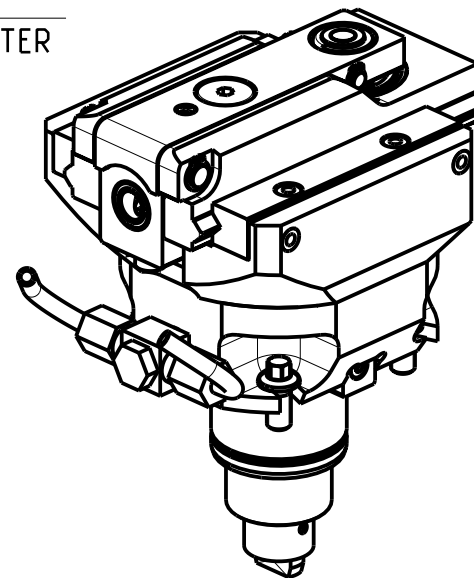

**DOTAZIONI - SUPPLIED WITH - AUSSTATTUNG**

N°1 Boccola di riduz. Ø16-Ø12 e N°1 Boccola di riduz. Ø16-Ø10  
 N°1 Reduction bush Ø16-Ø12 and N°1 Reduction bush Ø16-Ø10  
 N°1 Reduzierbuchsen Ø16-Ø12 und N°1 Reduzierbuchsen Ø16-Ø10

PER UTENSILI STOZZATORI VEDI PAG. TBL400-1-00  
 FOR DRIVEN SLOTTING TOOL CUTTING-TOOLS SEE PAGE TBL400-1-00  
 FÜR NUTENSTOSS-WERKZEUG SCHNEIDWERKZEUGE SIEHE SEITE TBL400-1-00

Cod. MT	I	RPM max n1	Reversibile 180° 180° Reversible 180° umsetzbar	Lubr. esterna Ext. coolant Aussenkuehlung	Lav. secco Dry-run Trocken Bearb.
DW01870200	4:1	2400	X	X	-

**HARD INGE**

MOD: T-42 16ST. - TALENT 42/51 12/16ST. - TALENT TT42/51 16ST. - CONQUEST H51 16ST. (BMT45)

MODULO MOTORIZZATO STOZZATORE CORSA 25mm H=75mm

Slotting driven tool 25mm stroke H=75mm

Keilnutenstossmaschine 25mm Hub H=75mm

Subject to change without notice.

**M.T. srl**

Via Casino Albini 480  
 Tel. 0541/956034-957884  
 Fax 0541/956341  
 47842 S. GIOVANNI IN M. (RN)  
 e-mail: mtma@mtmarchetti.com  
 http://www.mtmarchetti.com



HRD360-1-02