

-LA FUNZIONE DI POLIGONATURA/DENTATURA DEVE ESSERE INSTALLATA SULLA MACCHINA
 -POLYGON CUTTING/GEAR HOBBIING FUNCTION MUST BE INSTALLED ON THE MACHINE
 -DIE FUNKTION FÜR POLYGON-BZW. VERZÄHNUNGSFRÄSEN MUSS AUF DER MASCHINE FREIGESCHALTET WERDEN

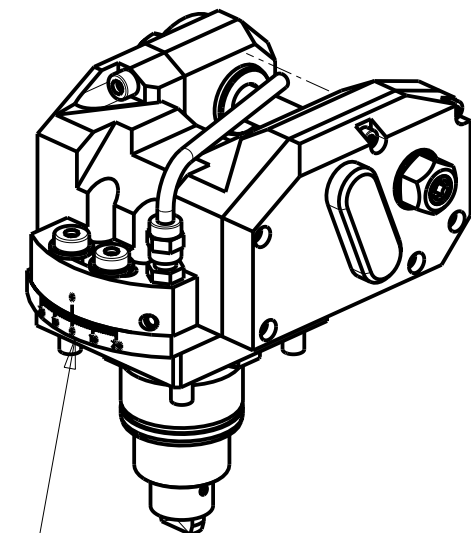

INCLINAZIONE REGOLABILE ±20°

Cod. MT	I (n1:n2)	RPM max n2	Coppia Max Max Torque Max Drehmoment M2 (Nm)	Lubr.esterna Ext. coolant Aussenkuehlung	Lav. secco Dry-run Trocken Bearb.	D	CHIAVI INCLUSE Keys included Schluessel inbegriffen				
DW 01611116	1:1	6000	30	X	X	16	CHUB19	CHESL06	CHESL05	-	-
DW 01611113	1:1	6000	30	X	X	13	CHUB19	CHESL06	CHESL05	-	-
DW 01611110	1:1	6000	30	X	X	10	CHUB19	CHESL06	CHESL05	-	CHUB17
DW 01611108	1:1	6000	30	X	X	8	CHUB19	CHESL06	CHESL05	CHESL04	CHUB13
DW 01611155	1:1	6000	30	X	X	1/2"	CHUB19	CHESL06	CHESL05	-	-
DW 01612116	2:1	3000	50	X	X	16	CHUB19	CHESL06	CHESL05	-	-
DW 01612113	2:1	3000	50	X	X	13	CHUB19	CHESL06	CHESL05	-	-
DW 01612110	2:1	3000	50	X	X	10	CHUB19	CHESL06	CHESL05	-	CHUB17
DW 01612108	2:1	3000	50	X	X	8	CHUB19	CHESL06	CHESL05	CHESL04	CHUB13
DW 01612155	2:1	3000	50	X	X	1/2"	CHUB19	CHESL06	CHESL05	-	-

HARD INGE

MOD: T-42 16ST. - TALENT 42/51 12/16ST. - TALENT TT42/51 16ST. - CONQUEST H51 16ST. (BMT45)

MODULO MOTORIZZATO PORTACREATORE

Driven gear hobber

Angetriebenes Zahnradwaeltzraes-Werkzeug

Subject to change without notice.

M.T. srl
 Via Casino Albini 480
 Tel. 0541/956034-957884
 Fax 0541/956341
 47842 S. GIOVANNI IN M. (RN)
 e-mail: mtma@mtmarchetti.com
 http://www.mtmarchetti.com



HRD340-1-20