

ATTENZIONE - ATTENTION - ACHTUNG

- Per lo smontaggio degli utensili utilizzare sempre la chiave di contrasto come indicato nel manuale d'uso.
- For disassembly of the tools use always the contrast key as mentioned in the user instructions.
- Fuer das Abmontieren der Werkzeuge immer den Gegenschlüssel benutzen wie in der Bedienungsanleitung erwäehnt.

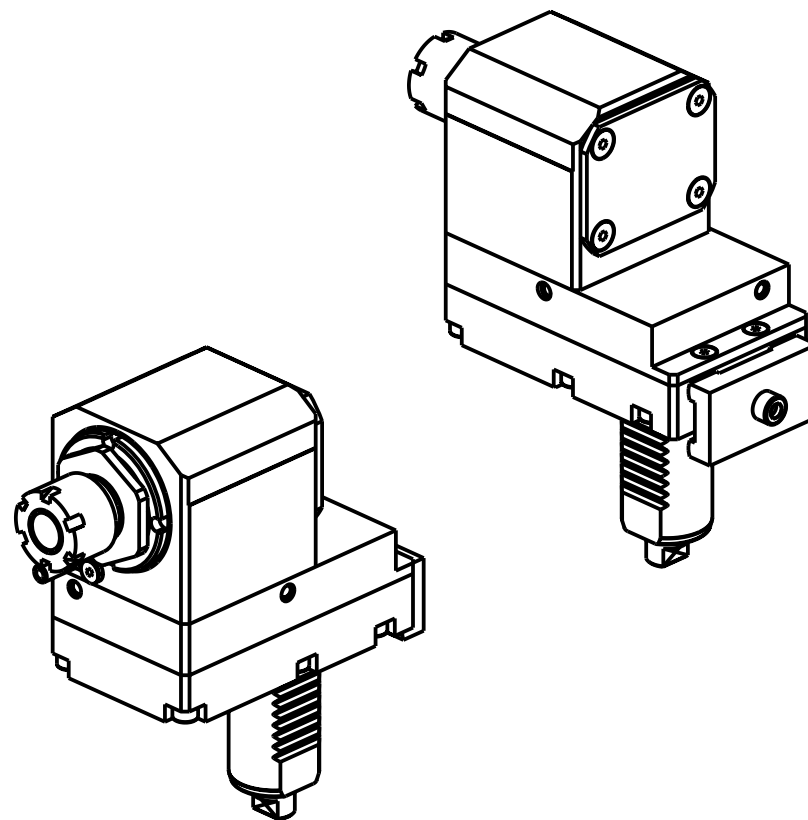

Cod. MT	Mandrino Spindle Spindel	I (n1:n2)	RPM max n2	Coppia Max Max Torque Max Drehmoment M2 (Nm)	Lubr.esterna Ext. coolant Aussenkuehlung	Lav. secco Dry-run Trocken Bearb.	CHIAVI NON INCLUSE Keys not included Schluesssel nicht einbegriffen
HNW 0020120	ER20	1:1	6000	16	X	X	CHUB38 CHMNER20

HANW HA
 MOD: STL32H/35H/38H (Y3) - STL42H/N/NH (Y3) (VDI30)

MODULO MOTORIZZATO RADIALE ARRETRATO VDI30
 Radial rear-set driven tool VDI30
 Radial angetriebenes Werkzeug zurueckversetzt VDI30

Subject to change without notice.

M.T. srl

Via Casino Albini 480
 Tel. 0541/956034-957884
 Fax 0541/956341
 47842 S. GIOVANNI IN M. (RN)
 e-mail: mtma@mtmarchetti.com
 http://www.mtmarchetti.com



HNW 018-1-10