

ATTENZIONE - ATTENTION - ACHTUNG

- Per lo smontaggio degli utensili utilizzare sempre la chiave di contrasto come indicato nel manuale d'uso.
- For disassembly of the tools use always the contrast key as mentioned in the user instructions.
- Fuer das Abmontieren der Werkzeuge immer den Gegenschlüssel benutzen wie in der Bedienungsanleitung erwaehnt.

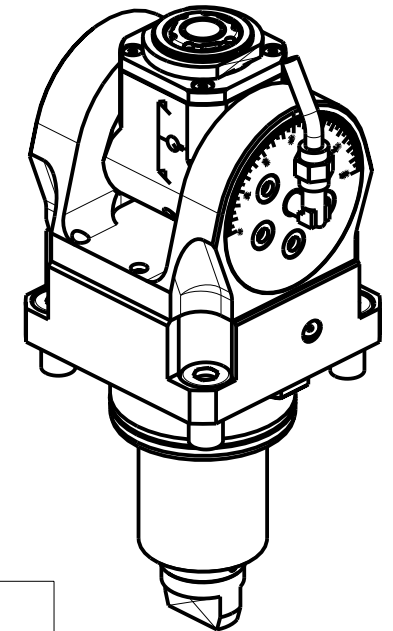

Cod. MT	Mandrino Spindle Spindel	I (n1:n2)	RPM max n2	Coppia Max Max Torque Max Drehmoment M2 (Nm)	Reversibile 180° 180° Reversible 180° umsetzbar	Lubrificazione int. Coolant through Innenkuehlung Pmax (bar)	Lubr.esterna Ext. coolant Aussenkuehlung	Lav. secco Dry-run Trocken Bearb.	CHIAVI INCLUSE Keys included Schluessel inbegriffen			
DW01940120	ERA20	1:1	6000	30	X	-	X	X	CHUB36	CHUB22	CHTAER20ZC	CHESL08
DW01940220	ERA20	1:1	6000	30	X	70	X	-	CHUB36	CHUB22	CHTAER20ZC	CHESL08

HAAS
 MOD: ST20/25/28/30/35 (BMT65) - DS30 (BMT65) - SB28/35 (BMT65)

MODULO MOTORIZZATO ORIENTABILE $\pm 90^\circ$ H=72mm
 $\pm 90^\circ$ adjustable angle driven tool H=72mm
 Angetriebenes Werkzeug schwenkbar $\pm 90^\circ$ H=72mm

Subject to change without notice.

M.T. srl
 Via Casino Albini 480
 Tel. 0541/956034-957884
 Fax 0541/956341
 47842 S. GIOVANNI IN M. (RN)
 e-mail: mtma@mtmarchetti.com
 http://www.mtmarchetti.com

