

**ATTENZIONE - ATTENTION - ACHTUNG**

- VERIFICARE LE MISURE DI INGOMBRO PER POSSIBILE INTERFERENZA SU ALCUNI MODELLI DI MACCHINE
- Please check the overall sizes for possible interferences on some machine models
- Bitte überprüfen sie das ausmass um mögliche interferenzen auf einigen maschinen modellen zu vermeiden

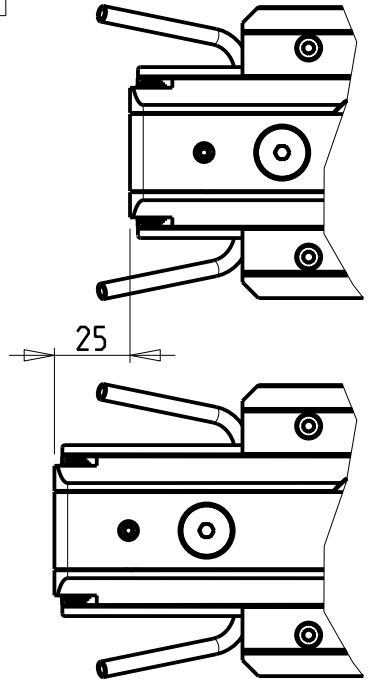
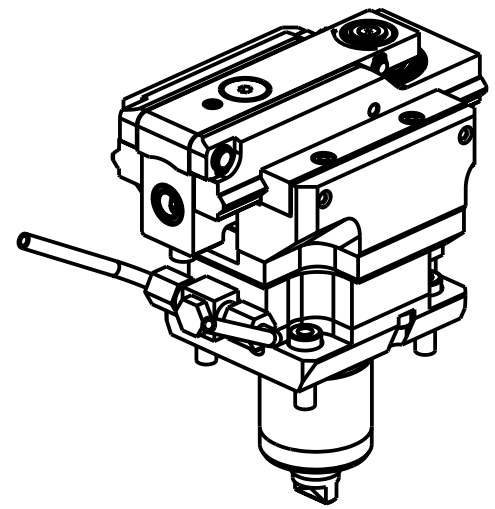

**DOTAZIONI - SUPPLIED WITH - AUSSTATTUNG**

- N°1 Boccola di riduz.  $\phi 16-\phi 12$  e N°1 Boccola di riduz.  $\phi 16-\phi 10$
- N°1 Reduction bush  $\phi 16-\phi 12$  and N°1 Reduction bush  $\phi 16-\phi 10$
- N°1 Reduzierbuchsen  $\phi 16-\phi 12$  und N°1 Reduzierbuchsen  $\phi 16-\phi 10$

PER UTENSILI STOZZATORI VEDI PAG. TBL400-1-00  
 FOR DRIVEN SLOTTING TOOL CUTTING-TOOLS SEE PAGE TBL400-1-00  
 FÜR NUTENSTOSS-WERKZEUG SCHNEIDWERKZEUGE SIEHE SEITE TBL400-1-00

Cod. MT	I	RPM max n1	Reversibile 180° 180° Reversible 180° umsetzbar	Lubr. esterna Ext. coolant Aussenkuehlung	Lav. secco Dry-run Trocken Bearb.
MYA0050200	4:1	2400	X	X	-

**GOODWAY**  
 MOD: GLS-150/200M/Y - GLS-1500/2000LY/LYS - GTS-150MMX/XY - GTW-1500

MODULO MOTORIZZATO STOZZATORE CORSA 25mm H=85mm  
 Slotting driven tool 25mm stroke H=85mm  
 Keilnutenstossmaschine 25mm Hub H=85mm

**M.T. srl**  
 Via Casino Albini 480  
 Tel. 0541/956034-957884  
 Fax 0541/956341  
 47842 S. GIOVANNI IN M. (RN)  
 e-mail: mtma@mtmarchetti.com  
 http://www.mtmarchetti.com



GDW 360-5-01

Subject to change without notice.