

ATTENZIONE - ATTENTION - ACHTUNG

- Per lo smontaggio degli utensili utilizzare sempre la chiave di contrasto come indicato nel manuale d'uso.
- For disassembly of the tools use always the contrast key as mentioned in the user instructions.
- Fuer das Abmontieren der Werkzeuge immer den Gegenschlüssel benutzen wie in der Bedienungsanleitung erwäehnt.

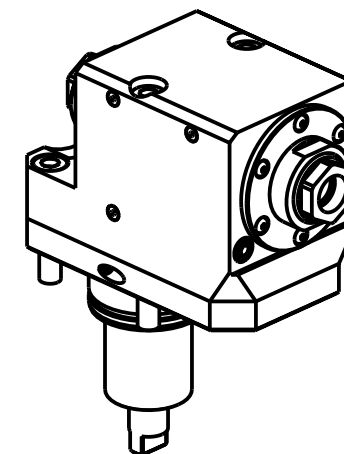
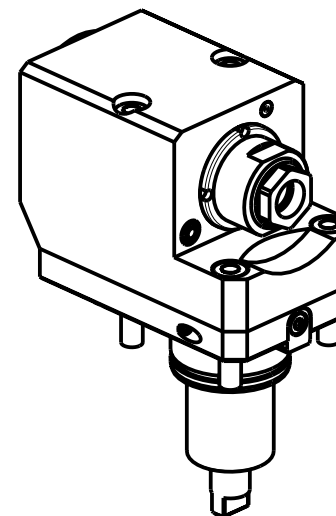

Cod. MT	Mandrino Spindle Spindel	I (n1:n2)	RPM max n2	Coppia Max Max Torque Max Drehmoment M2 [Nm]	Reversibile 180° 180° Reversible 180° umsetzbar	Lubr.esterna Ext. coolant Aussenkuehlung	Lav. secco Dry-run Trocken Bearb.	CHIAVI NON INCLUSE Keys not included Schlüssel nicht inbegriffen	
0632525	ERA25+ERA25	1:1	6000	50	X	X	X	CHUB27	CHUB38

GOODWAY

MOD: GTX2000/2600 16ST. - GTZ2000/2600 16ST.

MODULO MOTORIZZATO ASSIALE ARRETRATO BISPORGENTE

Axial opposite face rear-set driven tool

Axial angetriebenes Werkzeug zurueckversetzt halb vorspringend

Subject to change without notice.

M.T. srl

Via Casino Albini 480
Tel. 0541/956034-957884
Fax 0541/956341
47842 S. GIOVANNI IN M. (RN)
e-mail: mtma@mtmarchetti.com
http://www.mtmarchetti.com



GDW 243-3-10