

PER LAVORAZIONI INTERNE  
SU FORI Ø60 MINIMO

For machining internal  
holes with Ø60 min. hole

Fuer interne Bearbeitungen  
am loch minimum Ø60

**ATTENZIONE - ATTENTION - ACHTUNG**

- Per lo smontaggio degli utensili utilizzare sempre la chiave di contrasto come indicato nel manuale d'uso.
- For disassembly of the tools use always the contrast key as mentioned in the user instructions.
- Fuer das Abmontieren der Werkzeuge immer den Gegenschlüssel benutzen wie in der Bedienungsanleitung erwaehnt.

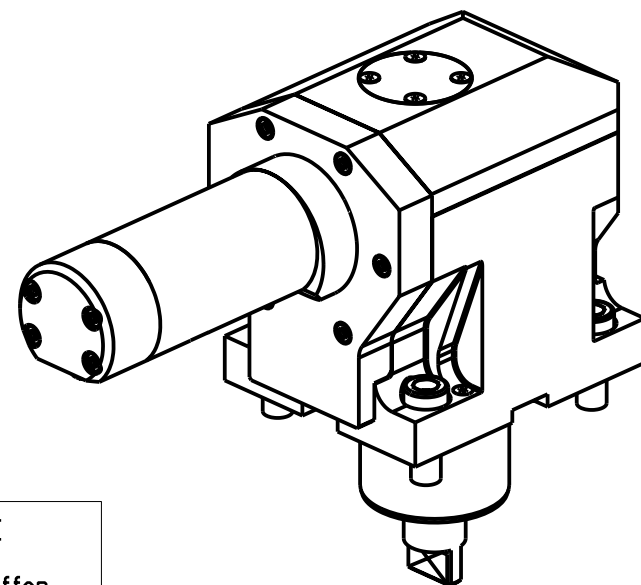
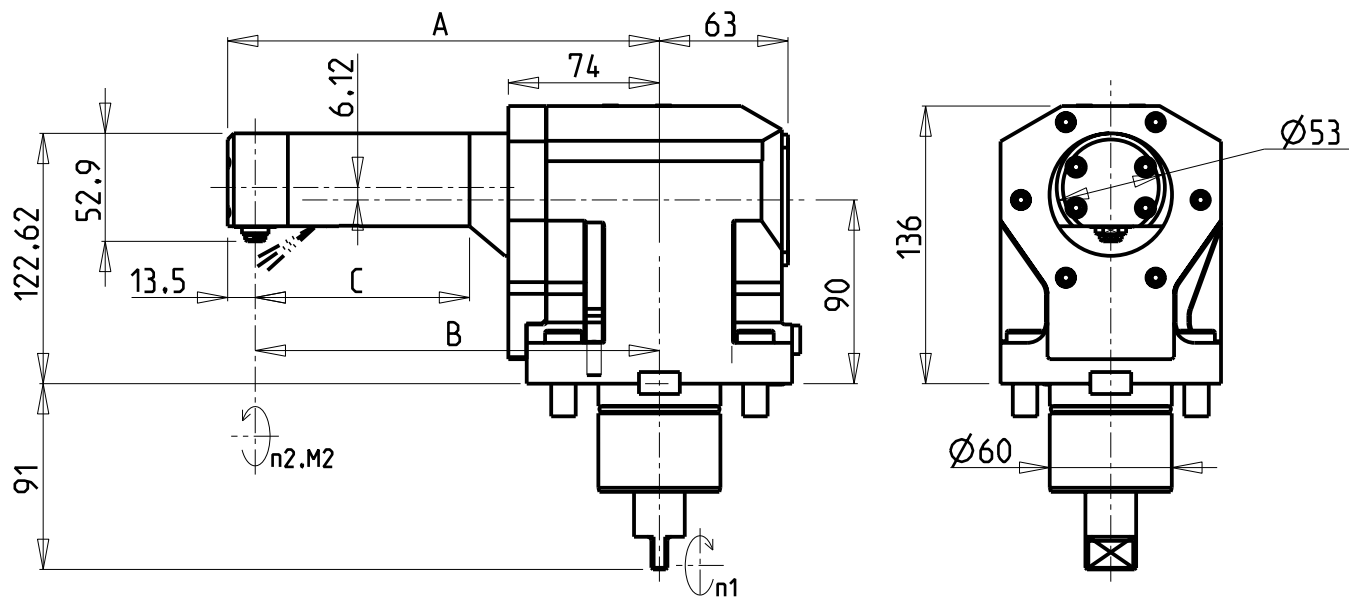

Cod. MT	Mandrino Spindle Spindel	I (n1:n2)	RPM max n2	Coppia Max Max Torque Max Drehmoment M2 (Nm)	Lubrificazione est. Ext. coolant Aussenkuehlung	Lav. secco Dry-run Trocken Bearb.	A	B	C	CHIAVI INCLUSE Keys included Schluessel einbegriffen	
GDW 0501055	CHG	1:1	6000	8	X	X	161.5	148	55	CHUB13_SP3	CHCHG10
GDW 0501105	CHG	1:1	6000	8	X	X	211.5	198	105	CHUB13_SP3	CHCHG10
GDW 0501155	CHG	1:1	6000	8	X	X	261.5	248	155	CHUB13_SP3	CHCHG10

GOODWAY  
MOD: GS2000/2600/2800/3000/3300/3600/4000 12ST. - GMS2000 12ST.

MODULO MOTORIZZATO RADIALE ROVESCiato DISASSATO IN Z  
Radial inverted driven tool re-directed in Z  
Radial angetriebenes Werkzeug umgedreht achsversetzt in Z

Subject to change without notice.

**M.T. srl**  
Via Casino Albini 480  
Tel. 0541/956034-957884  
Fax 0541/956341  
47842 S. GIOVANNI IN M. (RN)  
e-mail: mtma@mtmarchetti.com  
http://www.mtmarchetti.com



GDW 120-1-30