

ATTENZIONE - ATTENTION - ACHTUNG

- Per lo smontaggio degli utensili utilizzare sempre la chiave di contrasto come indicato nel manuale d'uso.
- For disassembly of the tools use always the contrast key as mentioned in the user instructions.
- Fuer das Abmontieren der Werkzeuge immer den Gegenschlüssel benutzen wie in der Bedienungsanleitung erwäehnt.

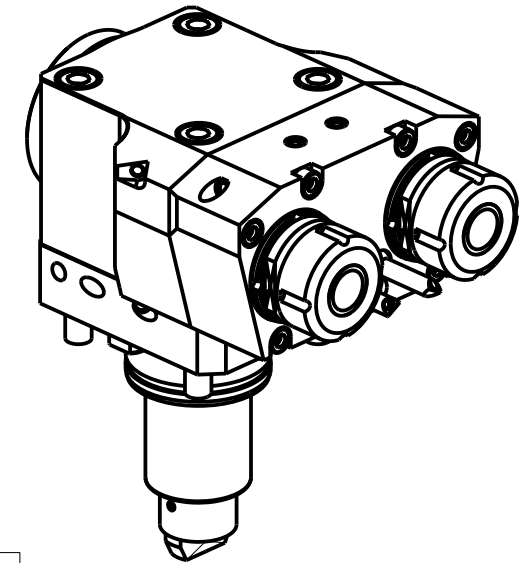
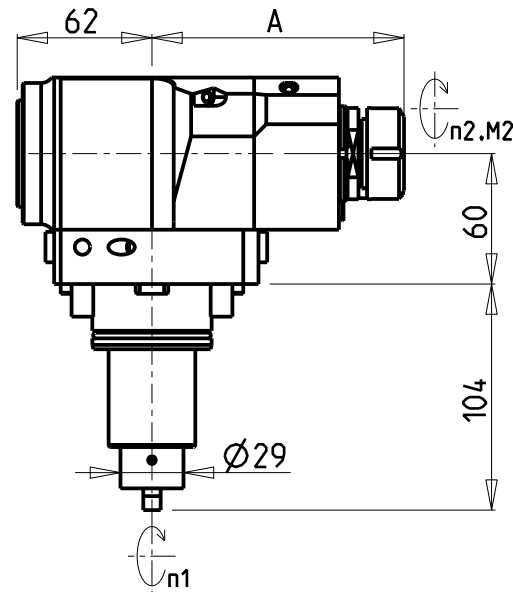
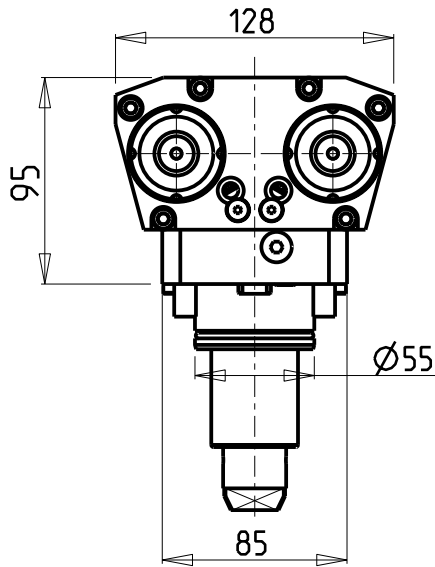
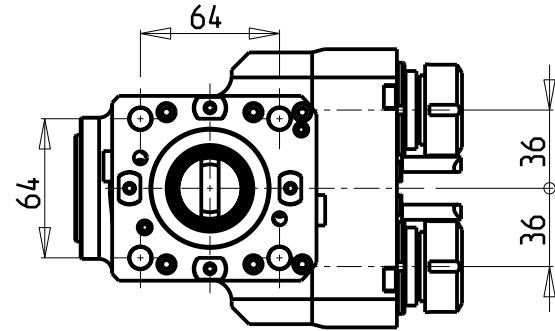

Cod. MT	Mandrino Spindle Spindel	I (n1:n2)	RPM max n2	Coppia Max Max Torque Max Drehmoment M2 [Nm]	Reversibile 180° 180° Reversible 180° umsetzbar	Lubr.esterna Ext. coolant Aussenkuehlung	Lav. secco Dry-run Trocken Bearb.	A	CHIAVI NON INCLUSE Keys not included Schluessel nicht einbegriffen	
									CHMNER16	CHUB17
DW 00950216	ER16	1:2	12000	20	X	X	X	115	CHMNER16	CHUB17
DW 00950225	ER25	1:2	12000	20	X	X	X	115.96	CHSTER25	CHUB36

DN SOLUTIONS (DOOSAN) BMT 55

MOD: PUMA 1500-2000-2100-2500-2600M/MS/Y/SY - PUMA TL2000-2500 (M)

MODULO MOTORIZZATO ASSIALE 2 USCITE IN Y MOLTIPLICATO I=1:2 H=60mm

Axial geared-up I=1:2 single side twin head driven tool in Y H=60mm

Axial angetriebenes Werkzeug 2 Ausgaenge in Y uebersetzt I=1:2 H=60mm

Subject to change without notice.

M.T. srl

Via Casino Albini 480
Tel. 0541/956034-957884
Fax 0541/956341
47842 S. GIOVANNI IN M. (RN)
e-mail: mtma@mtmarchetti.com
http://www.mtmarchetti.com



DW 0261-2-10